

## **Guide to Road Tax Vehicle Trials (RTV)**

### **1 – Scrutineering**

Scrutineering takes place before the event (check the 'calendar' page on our web site for full timings). In general if you have a standard vehicle in good road worthy order (with a fitted rear tow hitch) the only addition piece of kit required to be able to compete would be a front recovery point. The full regulations are available in the MSA Yearbook and ALRC Handbook. The following items will be checked on the day of the trial:

- Vehicle must have front and rear recovery points
- Suspension (condition and checks for non-compliant parts)
- Chassis condition
- Steering linkages will be checked
- The battery must be secured
- Seatbelts must be fitted and functional
- The hand brake must work
- The foot brake must work
- A 24mm, 3 strand, 8 ton minimum tow rope in nylon or polypropylene to be carried for recovery use
- Any load within the vehicle must be securely tied down.
- The silhouette of your vehicle will be checked to ensure it matches the size and shape of the vehicle as manufactured by Land Rover
- Tyre pressure (minimum 22psi)
- Fire extinguishers are advised but not essential.

### **2 – Signing on**

To sign on you'll need to present a valid membership card and pay your entry fee (as detailed on the club web site). The fee helps the club cover the cost of hiring the site. It also covers the MSA permit to run the event with any balance left being a contribution to the club to cover its operating costs.

Passengers are permitted in front seats aged 12 or over in hard tops and 16 or over in soft tops. Passengers (or their parent/guardian) must also sign on.

### **3 – Drivers Brief**

The drivers brief will be held just before the event start time (see club web site) and cover the following items:

- It is the drivers responsibility to assess whether or not to drive a section. There is no pressure to drive a section if you are not comfortable with it.
- Some of our sites contain bridleways/footpaths, please take care crossing these tracks and give priority to other users.
- If you come to an involuntary stop please don't continue to spin your wheels and dig holes, please consider vehicles yet to drive that section.
- Marshalls are to supervise all recoveries.
- Seat belts must be worn correctly whilst on a section. A three-point seat belt must be fitted across the shoulder as well as the waist.
- Drivers are not to start a section until they have been instructed by a marshal.
- No littering.
- Where the spill kits will be located
- Where the fire extinguishers will be located
- Who the clerk of the course is
- The running order
- The speed limit is 10mph, anyone found breaking this limit will be asked to leave.

### **4 – The Trial**

There are typically 8 sections to be completed during the event, each section is made up of 12 gates marked out by canes. The object is for a vehicle to complete the section non-stop without hitting a cane. Courses can only be driven once and it is encouraged you walk the section before attempting it. Long wheelbase vehicles (over 95" wheelbase) are permitted one shunt per section (consisting of one stop, reverse and restart manoeuvre). The gates are numbered 12 down to 1 and if a vehicle stops penalty points are awarded to the value of the gate the vehicle is approaching. Any canes hit will give a score of the struck cane. The winner is the driver who picks up the least penalty points.

Things to note:

- A shunt is one stop/reverse/recommence manoeuvre. Drivers must declare the manoeuvre is intentional by shouting 'shunt' before stopping. A shunt may not be used where a stop has been involuntary and should only be used if a driver fails to negotiate a tight turn. While reversing one wheel must be kept in the boundary of the course. The boundary can be assumed to be the

course as driven by the vehicle (ie its tracks). If a vehicle hits a gate while shunting the penalty is the same as if approaching the gate.

- A cane is hit if any part of the vehicle touches any part of the cane.
- If the vehicle ceases forward motion it has stopped, regardless of whether the wheels are still turning.
- Only one hub is required to get through a gate. For example if a vehicle gets one hub through gate 1 and stops before hitting the gate he/she will score 0. If the vehicle rolls back before acknowledgement from a marshal the score will be 1.
- Additional penalty point may be awarded for failure to wear a seatbelt, damage to the course through wheelspin where a marshal has instructed a vehicle to stop or for any other reason stated in the ALRC Handbook.

For examples of scoring please see overleaf.

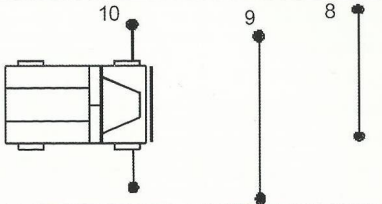
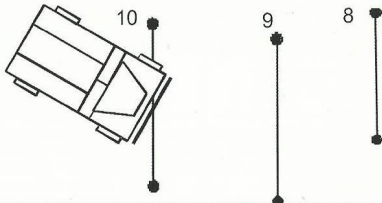
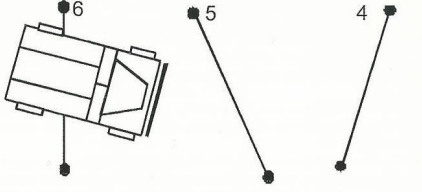
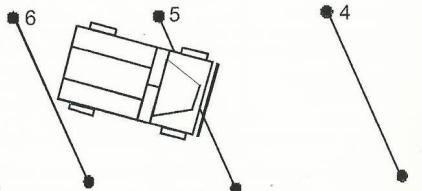
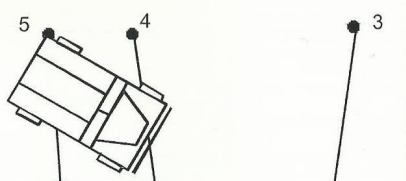
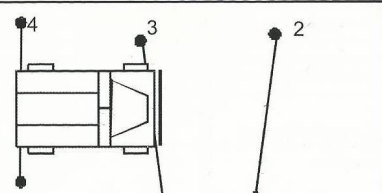
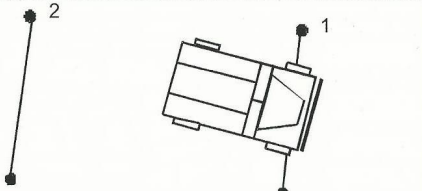
<p>SKETCH A</p> <p>Acceptable start position</p>	
<p>SKETCH B</p> <p>Acceptable start position</p>	
<p>SKETCH C</p> <p>Vehicle has stopped between 5 and 6.</p> <p>Penalty = 5</p>	
<p>SKETCH D</p> <p>Leading hub of stopped vehicle is between 5 &amp; 4.</p> <p>Penalty = 4</p>	
<p>SKETCH E</p> <p>Leading hub of stopped vehicle is between 4 &amp; 3 but has hit cane 5.</p> <p>Penalty = 5</p>	
<p>SKETCH F</p> <p>Vehicle has stopped with bumper between 3 &amp; 2 but leading hub is between 4 &amp; 3.</p> <p>Penalty = 3</p>	
<p>SKETCH G</p> <p>Vehicle has stopped with one hub on or just over finishing line.</p> <p>Penalty = 0</p>	
<p>SKETCH H</p> <p>Vehicle has gone outside course boundary during shunt or has simply gone too wide between gates 4 &amp; 3 despite the boundary being extended by crossed canes.</p> <p>Penalty = 3</p>	