

## Events for Your Diary

- \* First Wednesday of each month, Noggin & Natter at The Jolly Miller on the B3349, between M3 and Odiham aerodrome, Hants. (From 7:30 p.m. Plus Land Rover related videos if possible.). SU734517 approx.
- \* Last Wednesday of each month, Noggin & Natter at the Cob & Pen, Wallington, near Fareham, Hants. (From 7:30 p.m. Plus Land Rover related videos if possible.). Grid ref SU583 068 approx.
- \* Green-lane trips will usually be as advertised elsewhere. There will be someone present to indicate rights of way on the maps. Please bring your own maps of Hampshire and Berkshire, in case you get lost. If there is a lot of rain on the few preceding days, anticipate postponement.

I've printed the dates of everything I know about at the moment so get your diaries out! Note that *provisional* events are printed in *italics*. Will event organisers please let me know when any of these is confirmed / changed / cancelled etc.. Major changes, cancellations etc. are highlighted in **bold text**.

Short-term events programme is shown below; longer term programme can be found inside the back cover.

WS = Winter Series. SS = Summer Series.

Green laners:-

See article elsewhere for details of the next trip(s).

Feb 11	RTV (WS6). Surrey Sawmills. Details elsewhere this issue.
Feb 24	Ten pin bowling. Guildford. Details elsewhere this issue.
March 4	Green Lane trip. Hindhead area. Details elsewhere this issue.
March 11	Trial (WS7) Hook End Farm. Camping. Details next month.
March 18	<i>Club Driving Day (£10) CoC Ashley Pocock, and Tyro Trial (Free) CoC Steve Skinner. Broxhead Common.</i>
<b>Mar 31 - Apr 1</b>	<b>Camping and Laning weekend. CANCELLED</b>
April 12 - 17	<i>Easter Rally. RTV, gymkhana etc. Nelly's Dell. Programme later.</i>
May 6th	<i>Heritage Motor Run, Gaydon Museum. Details page 19.</i>
<b>May 5 - 7</b>	<b>RTV. Bow Hill. Bank Holiday weekend. CANCELLED</b>
12 - 13 May	<i>RTV Harroway Farm. Details later.</i>
May 18 - 20	LRO Show at Stoneleigh.



2001



# Pants & Barks

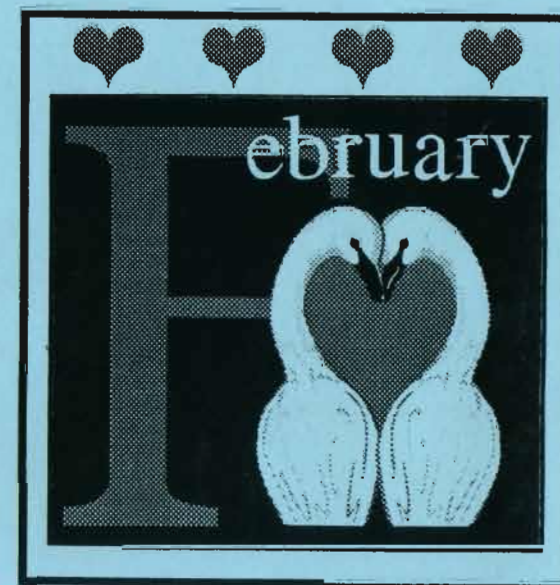

Newsletter of the  
Hants and Berks  
Rover Owners

## Officers of the Club

### \*CHAIRMAN

Nick van den Braak, 62 New Road, Clanfield, Waterlooville,  
HANTS PO8 0NN Tel: 023-9259-7266 Fax: 023-9237-0666  
e-mail nick.sue@vandenbraak.fsnet.co.uk

### \*SECRETARY

Zoe Raval, 3, High walk, Fareham, HANTS PO15 6BS  
Tel 01329-318698. e-mail kraval@uk.xyratex.com

### \*COMPETITION SECRETARIES

Carol & Steve Skinner 33 Holly Close, Warsash, Southampton,  
Hants. SO31 7BW Tel: 01489-583397  
e-mail carol@cskinner26.fsnet.co.uk

### \*TREASURER,

Sue van den Braak, 62 New Road, Clanfield, Waterlooville,  
HANTS PO8 0NN Tel: 023-9259-7266 Fax: 023-9237-0666  
e-mail nick.sue@vandenbraak.fsnet.co.uk

### \*RIGHTS OF WAY OFFICER and SPECIAL EVENTS OFFICER

Ashley Pocock Ashley Pocock, 14 Kingsmead, Little Ann, Andover, HANTS. SP11 7PN  
Tel: 01264-710546, Fax: 01264-710973 Mobile: 0385-316269  
e-mail ashleypocock@compuserve.com

### \*SOCIAL & CAMPING SECRETARY

Sam Parker, 51 Dartmouth Road, Copnor, Portsmouth, HANTS. PO3 5DT  
Tel: 023-9263-9193 Mobile: 0802-346743 e-mail Sam.Parker@virgin.net

### \*MEMBERSHIP SEC & NEWSLETTER DISTRIBUTION

Jenny & Bob Davis, 2 Highland Close, Emsworth, HANTS PO10 7JP  
Tel/Fax: 01243-430070 e-mail bobjen.davis@virgin.net

### \*ARC LIAISON & NEWSLETTER EDITOR

Steve Kirby, 244 Staines Road, Twickenham, MIDD. TW2 5AR  
Tel / fax: 020-8287-0377  
e-mail Steve.Kirby@cwcom.net and Steve.J.Kirby@BritishAirways.com

### WEB SITE EDITOR

Ian Parker, address and e-mail as Sam Parker above. Mobile: 07941-451804

### CLUB SHOP

Sarah Bridger, 12 Queens Road, Fareham, Hants. PO16 0NN  
Tel: 01329 315200 e-mail sarah@bridgers.fsnet.co.uk

### ACSMC REPRESENTATIVE

Nigel Thorne, Barford Stream Cottage, Churt Road, Churt, Farnham,  
SURREY GU10 2QU.  
Tel: Home 01428-714581, office 01252-377744. Fax: 01252-377334.

### SCRUTINEERS:-

Steve Kirby #, Chris Homewood, Steve Skinner, Gary Hodgson, JJ Walker.

Notes:- \* committee member. # member of ARC Scrutineering Committee.

"Hants & Berks Rover Owners" is a member of the ARC (Association of Rover Clubs), the MSA (Motor Sports Association) and the ACSMC (Association of Central Southern Motor Clubs.)



## Editor's bit....

It's all a bit of a squeeze this month. The draft of P&B that I took to the committee meeting had 52 pages, with stuff still on the spike! There's a lot that just has to go in this month so some articles promised for this issue have been bumped to the March issue. It's not easy being an editor, you know. (Well actually it is, but don't tell anyone.)

Camping regs - please read the Camping Code on page 17 of the ARC Handbook. We're producing a set of highlights to be issued soon.

BILLING - we can have a club stand free - does anyone want to go and man it?

Thanks.

Steve Kirby.

## This month...

### Regulars:-

- Nick's Bits. (Chairman's chat.)
- Competition Secretaries' Bit.
- Green Lane News.
- Letters.
- Event Reports.
- For Sale.
- Events Diary.
- Welcome, New Members.

### Articles:-

- ARC Rule Change Proposals.
- The Land Rover Marque Day at the Heritage Motor Centre.
- ARC News 39.
- Club Shop listing.

### Next month.

(Held over due to lack of space this month.)

- Trip to Norway - Episode 3. The "Touristy Bit" concludes.
- LARA report.
- Armchair Comp Safari - Superb computer game reviewed by Colin Gross.
- Road Rage.
- New Year's Day laning trip.
- Event Report(s).
- Internet info...

In order to get the newsletter to you by a reasonable time, everything must get to me by the 20th of the month absolute latest. If you are posting or faxing something to me, give me a call to let me know it's coming in case it gets delayed or mis-routed. If you have a PC, you can send articles on 3½" or 5¼" disc and I'll return the disc afterwards if needed. Practically any word-processor format will do or use plain text. If you use Works, only version 3 or later, please. I've now changed to Publisher 97 so I can accept files in any Publisher format up to that version. Fax facility now available again. Alternatively try e-mail. If you send an attachment, please use plain Text (\*.txt file) or Rich Text (\*.rtf file) format preferably. Please include a brief explanatory message in the e-mail. My e-mail addresses are:- at work:- Steve.J.Kirby@BritishAirways.com and at home:- Steve.Kirby@cwcom.net To improve the chances of making contact, try sending messages to both addresses for the time being. Thanx.

## Nick's Bit's

I can't believe I am already writing this for the February Mag, doesn't time fly when you are enjoying yourself! Sue and I had some holiday owing to us from last year, so we decided as the HBRO calendar did not have an RTV arranged for the weekend 6<sup>th</sup> -7<sup>th</sup> January, we would take the caravan and go down to the New Forest for a few days. It had actually stopped raining! We went straight from work of the Friday night. We covered the 50 miles in exactly an hour; the tdi 90 pulls the 17-foot Abbey with ease, and averages about 25mpg in the process. The weather was bright and clear with the temperature below freezing when we arrived. We stayed on a Forestry Commission Site called Setthoms near Sway in the forest. I think it is the only Forestry Commission Site that is open all year. (Even over the Christmas holiday.) It is a lovely site set in amongst tall fir trees. This part of the forest is a bit hillier and the scenery is quite beautiful. The site has no amenities other than water taps and elsan disposal points. It has individual pitches and quite a few of these have electric hook up. We decided that as it was so cold we would have the hook up. We left the electric heating on all the time both night and day, but only running on tick over at night. The caravan remained very warm the whole time. We were so lucky with the weather. We had five days holiday and every day was fine. It stayed very cold but the days were bright and sunny. It was a lovely lazy break as Christmas had been quite hectic. All we did was read our books and walk the dog. 'Heaven.' But now we are back to work and reality.

I hope those of you that went to Brick Kiln enjoyed it as much as I did. Everyone has an opinion about this trial site; you either love it or hate it! Like most people I have done most of my Land Rover wrecking at Brick Kiln, however I would not miss a trial there for anything. It is normally thrills all the way. With nearly three months of rain and half the country under water, we did not know how much of the site would be usable. The very deep holes in the woodland were avoided, as the COC, Chris Homewood, couldn't find anyone stupid enough to see how deep the water was! My guess would be half way up the windscreen! However, Chris and his team of helpers set out some very interesting sections. The one below the car track raised a few eyebrows. The start gate was up the top, gate nine down in the bottom on a side slope forty metres away, a sea of mud was in between. Did you go high and slide down through, or drop right down and then try to get back up to the gate? Well as you would have hoped on such an early gate, both options were possible - just! It was a really good, non-damaging trial. Honours went to our Comp Sec, Steve Skinner on 7 points, with yours truly one point adrift. Unfortunately, I did not make the Green Lane Trip on New Year's Day due to a serious leak of power steering fluid, a litre a day would you believe, (now fixed). However I have heard excellent reports. Thank you Jimmy. Harroway Farm was the venue for the RTV on the 14<sup>th</sup> January, again with many of the villages around flooded we did not know if this site would be usable. As it happens, it stopped raining and we had a couple of weeks of very cold weather. The weekend of the trial was bright and sunny, beautiful clear blue skies on both days, but extremely cold. Kiran Raval was COC and with his band of helpers he set out another really good non-damaging trial. There had been a very severe ground frost on the Saturday night, which meant that the sections generally did not cut up too badly. However the areas out of the biting wind that the sun got to became very slippery. Towards the end of the day, the later vehicles to drive a section were getting stuck as the ground became muddier. Paul Homewood took the honors that day, with a very clear win. Well done

Paul, I have a feeling that this is the first of many wins!

Nick van den Braak HBRO Chairman

---

## BRICK KILN DEC 16/17 RTV

Well Brick Kiln certainly lived up to its reputation of being cold and muddy! This became clear as soon as we turned up to help the hardy souls who turned out on Saturday to set out. We were greeted with a biting Northerly wind and light snow flurries, but that old HBRO press on regardless spirit was in abundance; we must be BARKING!!!

Chris Homewood was the COC for the weekend and managed to set out some very interesting sections along with the team ready for the triallers on Sunday.

Sunday morning dawned bright and crisp, just right for a days mud plugging.

Eleven of us signed on as competitors for the last trial of 2000. What turned out to be a real test of our skills etc. ensued with the ground feeling more like ice than the mud that it was. However it seemed to suit Nick & Sue VDB and Carol & Me as we battled with each other all day to lead. In the end we just managed to pip them by one point. It doesn't get any closer than that!

What was a surprise was that we both managed to beat Andy Bridger, so you see it can be done! And yes I am gloating... Everyone seemed to have a good time, none more so than Mike & Kay Wood who managed to get a GONG for second in class in their very first trial for goodness sake !!!

Results as follows:-

Class 3:

Matt Hewitt 15 Paul Holmwood 24

Class 4:

Nick Van Den Braak 8 Mike Wood 24 Neil Tomlinson 38 Adrian Bourne 48

Class 5b

Jeff Pavitt 29 Andy Jones 33

Class 8

Steve Skinner 7 Andy Burgess 21

Class 10

Andy Bridger 17

Setting Out Officials: Chris Homewood (COC) Nick & Sue VDB, Mike Wood, Gary & Paul Homewood, Karen Duffett, Carol & Me.

Officials for trial: Chris Homewood (COC) Brenda Taylor (Secretary) S Skinner (Scrutineer) Hugh Duffett (Chief Marshal) Richard Butterfield and Trish Jacobs Marshals. MANY THANKS.

Steve Skinner

## ARC Handbook 2000

Have you all now got the ARC2000 Green Book?. If you do not have one please come along to a club event, either social or competitive, and ask for your free copy. It is quite a heavy publication and is some what expensive to post to members, so please make an effort to obtain one and help the stockist (Jenny Davis, Zoë Raval & Nick Jennings) empty their spare rooms.

In the Green Book, please make a point to read Section H.35 Promotional Events 1-4 and bear these regulations in mind. They are there for your safety.

There won't be a 2001 edition, so look after the one you have!

---

## ARC2000 - Acknowledgements Thanks Everybody !!!!

I had the best of intentions to publish the names of the "guilty" parties in the P&B but due to excessive amounts of this work thing I am sorry to say I have not completed the transcription of all of the names across to the computer. If I ever get time, I will complete the task, but needless to say, you know who you are, (and so do I), and the Club has immense pride in you achieving what appeared to some to be an unscalable challenge. The job is done, and now we need to focus again on the business of growing one of the most successful LR Clubs in the Country.

Have gggreat Christmas and see you Green laning or the next event.  
Ash.

---

## 4x4 Playthings

North Staffs 4x4 Centre's latest Formula 4x4 catalogue 2000 of 4x4 accessories is an Aladdin's cave. It's free from them at Stafford Road, Stone, Staffs, ST15 0UN. Tel: 01785-811211, fax: 01785-285500, e-mail [info@ns4x4.co.uk](mailto:info@ns4x4.co.uk), website [www.ns4x4.co.uk](http://www.ns4x4.co.uk).

Malcolm Rain

---

## Welcome New Members

Simon Brown, Fareham  
Sarah Clark, Fareham  
Christopher Osborn, Alton.

Andrew Burgess, Farnham.  
John Knight, Portsmouth.  
Terry White, Bournemouth.

## REME Museum

We have been given a rare opportunity to visit the REME Museum and 'possibly' workshops in Bordon, courtesy Barry Simpson and his connections in the right places. The date will be Sunday 4<sup>th</sup> March 2001, and admission will be only by pre-booking with Barry, due to the security restrictions required to access this Military site. A charge for visit will be made of £5/adult and £2/child (over 10) - the proceeds will go to the REME nominated charity. The curator of the Museum will supervise the visit, and Tea and Coffee included in the fee.

Anyone wishing to attend this special insight into the Heavy and Light vehicles used by the British Army, must contact Barry Simpson on 0208 8701804, by 15<sup>th</sup> February 2001, with names and vehicle registrations, to ensure admission and get final details.

Ash.

---

## Stolen Land Rover. Can you help?

I am a member of YROC and would appreciate your help and assistance in locating our missing LR vehicle and trailer.

Thanks.

Austin Laughton

J652 PUP White CSW 200TDi

Chassis SALLDVBF7JA916040. Engine 11L22135A. 80,000 Miles(ish)

Distinguishing features:-

All white indicator lenses. Galv front bumper. Galv Steering Guard. Galv Dixon Bate tow hitch, with 8 inch galvo spacer. Galv Ball. Galv "D" handles. Stainless CB gutter mount O/S. Full Length Side Steps. Double Fog lamps and Double Reverse Lamps at Rear. Stainless fittings to rear cross member. Windows etched. Shortened load space protector tray in the back, to make room for Aluminium Gun Holder. Running Michelin 7.50 x 16 XZY,

And just to add insult to injury:-

2.5 K UKPs worth of Ifor Williams trailer 14ft Twin axle. Ally chequer plate bed, using stainless screws. Ramps. Home made winch mount made from 6mm checker and Galvo'ed. Brand New Hand Winch with shortened handle. Replaced side retaining chains with Stainless chain. Inside wheels painted Blue. Just undersealed and waxoyled it. Added 3x marker lights down the side. Wagon reflective chevrons on the rear tail board. No spare wheel carrier. The whole lot was stored behind a very substantial gate and lock, loads of security lights etc etc. If you come across any of these bits contact the Police, or [Austin.Laughton@invensys.com](mailto:Austin.Laughton@invensys.com)

# Rights of Way News

**STOP PRESS** - Ian Parker has had to relinquish his post as "Rights of Way Officer" due to pressure of work. Ashley Pocock has taken over the position.

Green Lane Co-ordinator, Ashley Pocock  
Tel: 01264-710546, ashleypocock@compuserve.com

Here is a list of "area reps" so you can contact them to see what's on:-  
Nick van den Braak, South Downs / East Hants. Tel: 023-9259-7266  
Nigel Thorne, Hindhead / Haselmere Areas, 01428 714581.  
Nik Watts, North Hants Area, 07768 615377.  
Jimmy Salmon, Thames Valley / North Berks, 07774 680977.  
Richard Myers, South Wilts / Salisbury Plain area, 02380-455349.  
Ashley Pocock, Andover / Winchester areas. 01264-710546,

Forthcoming laning trips:-

### 4th March 2001 Frensham and Hindhead

To this end I am trying to run a trip locally to me on the 4th March 2001, start around 10am. I have arranged a route for "shiny" vehicles, newcomers and novices, but three lanes can be bypassed by these vehicles and fall into the "harder" green lane status. I would expect regular laners to run these in both directions.

Those who came last time will enjoy it as I intend running the route backwards, for those who left at lunchtime, and to pick up any missed lanes.

Time overall should be about four hours running with a stop for lunch. Please let me know if you are interested and if any other details are required. Meet at my house from 9.30am, probably coffee or tea on the brew. (Address and tel inside front cover) Grid Ref SU853381

From Hindhead take A287 towards Farnham, at Crossways pub in Churt turn left, 300 yards on right is black and white cottage. From Farnham take A287 towards Hindhead and Frensham, past Frensham Pond to Churt Village turn right at Crossways pub and 300 yards on the right.

The route should give some great scenery as well as good laning.

Nigel Thorne.

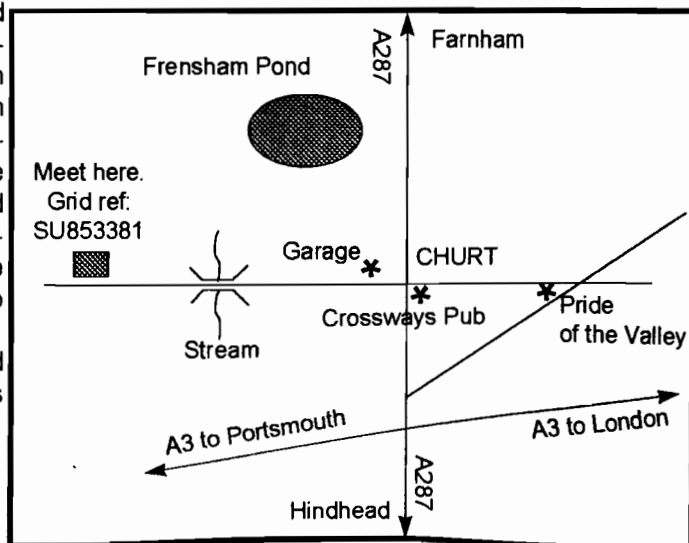

# Rule Change Proposals 2000

Here are the rule change proposals to be voted on for the 2001 ARC AGM. At the end of each proposal, in bold text, is the view of the ARC Scrutineering & Off-Road Committee.

(1) Following a question from YROC in 1999 regarding inset windscreens and hood stick sizes, the following rule change is proposed:-

The following sentence is to be added to the end of RTV Trials vehicles rule E.1.1.1.:-  
**"The windscreen has to be the manufacturer's framed windscreen and not a home made variety where the glass is fitted into the front hoop of the rollover cage. The hood sticks and tilt have to be full size, and the same size and shape as the original"**

This matter was discussed at the Scrutineering Group meeting of April 24<sup>th</sup> 1999 and the response was published in ARC News 28, July 1999.

**Recommended.**

(2) Proposal from Colin Council.

"I would like to propose that Rule C.2.2. be amended. The aim of this proposal is to keep the sport affordable to all by restricting the modifications allowed to be done to injection systems. Rule C.2.2. to read as follows: Non-standard carburation and manifolds are allowed with the exception of petrol injection components which must be as standard to the engine type fitted and have a Rover part number."

**NOT recommended but agreed it should go for a membership vote.**

(3a) Proposal from HBRO, Use of parabolic springs

We propose a change to the Standard Class Regulations. Specifically the use of Parabolic Leaf Springs as designed by Santana, a licensed builder of Land Rover in Europe. Original Proposal:-

Recommend that the wording of para. B.3.1 changed to:- **"Leaf springs shall not have less than 2 leaves. This allows the use of leaf springs built to the Santana parabolic designs"**

Nick van den Braak, Chairman HBRO, Zoe Raval, Secretary HBRO.

(3a) Amended Proposal:-

The wording of the original proposal does not meet the specific requirement to permit only parabolic springs of the Santana design. Consequently, the proposal is amended and rule B.3.1. is to be amended to read:-

**B.3.1. Road springs shall be the same type as those fitted as standard for the vehicle concerned. Standard leaf springs shall not have less than 5 leaves. If the springs have been rebuilt, the leaves below the top two MUST be in proportional reducing steps to copy the originals. "Tin foil" or "Spacer" designs are not acceptable. 101" wheelbase Forward Control Land Rovers must have at**

least two leaves on each spring. Parabolic springs with at least two leaves to the Santana parabolic design are also permitted. In all cases, the second leaf should wrap around the eye.

**Recommend the amended version.**

(4) Proposed rule changes for competitive vehicle classes

I am putting forward the following proposals for changes to the Comp. Safari class structure mainly to further promote the use of standard vehicles for competition. This is a matter we have been trying, as an association, for some time to encourage yet, with our class structure as it currently stands, we actually discourage the use of the standard vehicle.

Currently if a member wishes to comp. safari a ninety/swb defender, unless it is fitted with a turbo-diesel engine, he or she would be placed in either class 8 or 9. There is no way that a vehicle with the engine fitted in the standard place and standard location/travel for the suspension can be remotely competitive in either of these classes. The 2.5 litre ninety has maybe 80 bhp against a V6 special of at least 170 bhp with almost mid-mounted engine and vastly superior suspension (class 8). A 3.5 litre V8 ninety can get a little closer on power but still faces the same problems with weight distribution and suspension. Added to this is the fact that a special with replica "series one" body panels allows the driver and navigator to sit on (or even lower than the tops of) the chassis rails, thus lowering the centre of gravity substantially, and the driver of a ninety has to sit at least 6 inches above the chassis just to see over the body.

Proposal :

Combine class 3 and class 5 for comp. safari so that there is one class for LWB vehicles. To read;

**"Class 3 Standard. Petrol engine long wheel based (100inch and over) vehicles".**

This would include all petrol Range Rovers, Discoveries, Freelanders, 110s, 127s, 130s and their Defender equivalents. Any new factory vehicles over 100 inches would automatically go into this class.

Change class 4 to read;

**"Class 4 Standard. All diesel engine models."**

Change class 5 to read;

**"Class 5 Standard. Petrol engine short wheel base (under 100inch) vehicles."**

Delete the reference to "Ninety" from classes 8 and 9.

The above proposal will incorporate any likely new vehicle into classes 3, 4 or 5. It will leave classes 1 and 2 alone to cater for the series Land Rovers and classes 6 to 9 will cater for the specials builders. Hopefully this will go some way towards future proofing the regulations without adding to the number of classes.

This situation with the ninety really does need to be addressed as it was raised at the last P & D National some years ago, where I was assured by a senior ARC officer that he would "personally take the matter on board and it would be resolved". I have not held my breath waiting.

We need to get on with supporting the "standard vehicle" and if the above changes are incorporated, then the use of the ninety for comp. safari will get a real boost.

Colin Gaukroger, President, L&CROC.

**Recommended.**

Rule change proposals from the Scrutineering & Off Road Committee (1) to (14), from individuals and from clubs All to be considered and voted upon separately.

(5) When the Land Rover 90 first appeared, it was placed in the classes that seemed best suited to its capabilities. Requests for other suggestions were made to the ARC membership several times but no alternative ideas were forthcoming.

Proposal:-

New arrangement for Competitive Safari classes:-

**A.2.2. Competitive Safari.**

- Class 1 Standard Leaf sprung. Up to 2000cc 4 cylinder petrol and up to 2286cc diesel engine.
- Class 2 Standard Leaf sprung. 2001cc to 2495cc petrol or 2287cc to 2495cc diesel & LWB 2625cc 6 cylinder petrol.
- Class 3. Standard Ninety / SWB Defender (Petrol)
- Class 4 Standard. All models with Turbo-diesel engines.
- Class 5 Standard. Range Rover, Discovery, 110 / LWB Defender, Freelander, all FC's & LWB-V8. (Petrol)
- Class 6 Special Leaf sprung up to 3000cc.
- Class 7 Special Leaf sprung above 3000cc.
- Class 8 Special Coil sprung up to 3000cc.
- Class 9 Special Coil sprung above 3000cc.

**Recommended.**

(6) It has come to our attention that a significant number of chassis have been manufactured commercially and sold to ARC members as being ARC-legal. It appears that some of these have escaped the attention of the log book scrutineers and some have been spotted and allowed to run "under appeal" for a limited period while a decision is made on a recovery plan. There maybe more to come. Nearly all the Committee members have been consulted and agree that this design is perfectly satisfactory; but it is not in the ARC Handbook. Consequently, we propose that the design be added to the Handbook as an acceptable design.

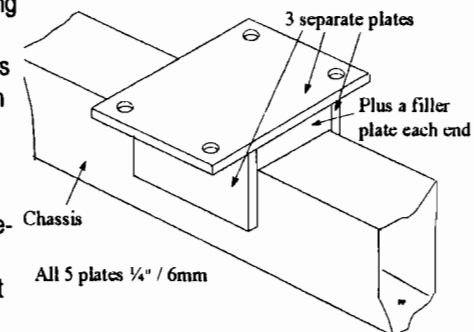

Proposal:-

The design for a roll-cage mount shown here be added to the ARC Handbook.

**Recommended.**

(7) Additional wording for the rule on fuel tank sealing:-

A.11.1. All fuel tanks must be securely fixed in place, be of metal construction, have a leakproof cap and be isolated from the driver / passenger compartment by the best possible method commensurate with the vehicle design. **A non-return valve incor-**

porated in the vent system is recommended. Vents should be designed to avoid spillage if the vehicle becomes inverted. Underseat lids should be screwed down with a gasket. The very minimum protection for an early underseat filler is the cap separately sealed.

Most of this is covered by existing MSA regs but a summary such as this may be a good way to go.

**Recommended.**

(8) Additional paragraph for the rule on fuel tanks:-

**A.11.4. LPG systems must conform with Construction and Use regulations and LPG Industry Technical Association Code of Practice No. 11. If the cylinder is installed internally, then it will need to be protected against damage by being covered. Internally fitted cylinders come with a cover for the tank fittings but generally no overall cover. A removable wooden cover will suffice.**

**Recommended.**

(9) Revised and enhanced wording for the rule on silhouette:-

A.12.3. Bonnets.

**A.12.3.1. Bonnets must be retained in place.**

**A.12.3.2. Fibreglass bonnets are allowed if they have been made from non-flammable resin. The onus is on the competitor to prove this by showing a document or some form of proof from the manufacturer stating that it is made from fire-retardant material.**

**A.12.3.3. If the vehicle has a permanently fitted windscreen, then the bonnet may have holes, louvres, air-scoops etc. If there is no permanently fitted windscreen, then holes, louvres, air-scoops etc. are not permitted.**

**Recommended.**

(10) Additional paragraph for the rule on steering.

**A.6.5. High-strength one-piece steering rods made of thick-walled tube or solid bar are permitted. Locking will be by the use of lock-nuts, not clamps. (This is the same design as the "SUMO" bars accepted at the AGM of 16th March 1991).**

**Recommended.**

(11) Additional wording for the rule on Bodywork:-

**E.1.1.2. The whole of the manufacturer's hardtop or truck cab, appropriate for that model, with all fastenings secured and all glass in position.**

**Recommended.**

(12) Additional paragraph for the rule on Bodywork:-

**E.1.3. The tilt and "cage" as used on the SV90 models is acceptable instead of the standard tilt-frame.**

**Recommended.**

(13) Additional paragraph for the rule on suspension:-

**B.3.4. Metal ball-joints (commonly referred to as Rose-Joints) are not permitted as substitutes for rubber bush fittings on any radius arms or panhard rods.**

**Recommended.**

(14) Additional wording for the rule on steering:-

**A.6.1. Under no circumstances will steering gear parts that have been cut, cut-out, bent, broken or welded be allowed. Post-manufacture welding of steering gear parts is not permitted.**

**Recommended.**

(15) Additional wording for the rule on shock absorbers / dampers:-

**A.10.2. Axle check straps are not mandatory. A full complement of factory-specification bump-stops must be fitted in appropriate place. These bump-stops must be complete items that match either the chassis or axles in use."**

**Recommended.**

(16) Competition number boards for Comp Safari vehicles.

The following new rule is to provide guidelines on the implementation of the existing MSA requirements which apply already. It includes details to accommodate different vehicle styles.

**G.11. Competition number boards\*.**

**G.11.1. Vehicles with exposed rear braces - number boards to be attached to the rear braces. This is very simple and these boards can be exchanged to accommodate championship numbers very easily.**

**G.11.2. Full bodied vehicles should have the number boards above the waistline over the rear wheels. If the vehicle has windows then the number boards can be inside the windows. If the vehicle has sponsorship markings for other championships, then number boards can be attached temporarily over the fixed championship numbers.**

**\*Dimensions and colour to be as per MSA regulations. See MSA reg E.11.3.11.**

**Recommended.**

(17a) Detail description of seat-belt mounting philosophy. Rule A.3. to become:-

Original proposal:-

**A.3. Seats & Doors.**

**A.3.1. Seats must be firmly fixed and doors securely fastened.**

**A.3.2. Seat belt anchorage points - minimum specifications:-**

**RTV - Standard class, as per manufacturer's design. Special Class as per CCV, Comp Safari, Point-to-point and Team Recovery.**

**CCV, Comp Safari, Point-to-point and Team Recovery.**

**For Series and Defender style vehicles; the factory-standard anchorage points on 90 / Defender-type models onwards repre-**

sent the minimum specifications. Any vehicles prior to that requires anchoring either directly or indirectly to the chassis in the manner and materials of the Defender type installation.

For Range Rover / Discovery / Freelander vehicles; the factory-standard anchorage points should be retained.

As applicable, anchorage points on the roll-cage to the rear of the driver shall be as shown in the Roll-bar Regulations."

(17b) Amended proposal:-

**A.3. Seats & Doors.**

**A.3.1. Seats must be firmly fixed and doors securely fastened.**

**A.3.2. Seat belt anchorage points - minimum specifications:-**

*RTV & CCV - As per manufacturer's design. Pre-1965 vehicles must have belts mounted indirectly to the chassis.*

*Comp Safari, Point-to-point and Team Recovery.*

*For Series and Defender style vehicles; the factory-standard anchorage points represent the minimum specifications. Any vehicles prior to that requires anchoring directly to the chassis.*

For Range Rover / Discovery / Freelander vehicles; the factory-standard anchorage points should be retained.

As applicable, anchorage points on the roll-cage to the rear of the driver shall be as shown in the Roll-bar Regulations."

**Recommend the amended proposal.**

=====  
(18a) The rules relating to the ages of passengers in trials show that the ages are different depending on whether the vehicle is OPEN or CLOSED. This is not the same as having a hard-top or a soft-top. If the vehicle is OPEN, then the minimum age is 16. If it is closed or if it has a manufacturer's hard top, a truck cab, or a roll-bar, then the minimum age is 14 years. Consequently, E.5. needs to be amended thus:-

Original proposal:-

**E.5. PASSENGERS**

One passenger / navigator only, over the age of 14 years, allowed per vehicle if it has a manufacturer's hard top, a truck cab, or a roll-bar; 16 years for **an open** vehicle.

(18b) Amended proposal:-

**E.5. PASSENGERS**

One passenger / navigator only, over the age of 14 years, allowed per vehicle if it has a manufacturer's hard top, a truck cab, or a roll-bar; 16 years for **a soft-top** vehicle.

**Recommend the amended proposal.**

END

## I'm Taking the Off-Road

I've never been one to beef about the Club, having always taken the view that it takes all kinds to make a world - even a world where Land Rovers and Off-Roading take precedence. This I guess is where I'm having a slight problem - I love the activity side of the Club, and given the free time I'd be working on the Disco or Series one every week-end or driving / competing / organising. The mix of events we do, covering; Trials, Laning, Scenic drives, Gymkhanas, Rickshaw, etc., etc., have always stimulated me, alongside the opportunity to meet with like-minded people. The problem I have is that the Social side, seems to be steadily increasing in the Club's itinerary. I must admit this largely originated from my enthusiasm whilst Comp' Sec' to accommodate overnight camping at events so that members could help set-up on the Saturday, then relax at the site in the evening and be ready for our early starts on Sunday. However, with late night sessions, paintball, kids events, bowling, skittles, etc., I am not even sure that we are true to our constitution, or are complying with the requirements of our insurance (especially if we invite non-members to participate) in organising these activities. Most of all though, I am concerned about the views of our members. If the membership wants a social club then fine, I for one won't be renewing my membership, but that's my right to belong to a club that serves me as a Land Rover and Off-Road enthusiast. I am all for socialising as part of Off-Roading, but sometimes it seems the Club has reversed the roles and this I believe could alienate many members who are here for the mud and not necessarily the bud.

I think it is time to get our priorities right, if this Club is to survive in the form it has for many years - it needs to satisfy the interests for which it was created - Rover Ownership, and specifically the prime interest of members; Land Rovers.

We had a great event in ARC2000, the M-Team "took the biscuit", and the core Club spirit shone through, which is what we need to keep HBRO moving forward. I am certainly not backing away from my promise to support the Club, having been a member since 1986 and served 4/5 years as Comp' Sec' prior to taking on Managing ARC2000. To the contrary I have agreed to act as Special Events officer and become coordinator for the 'Area Laning' rep's. However, if I am on the wrong wavelength and the membership is happy to allow the Social Events to lead the Off-Road activities, then I will take my 'bat and ball' and go play elsewhere.

Yours, unable to suffer in silence,

Ashley Pocock.



# RTV Trial

## Surrey Saw Mills, Wrecclesham, Surrey.

### 11th February 2001.

<b>RTV Winter Series.</b>	<b>Facilities:-</b>	<b>Toilets in the trailer.</b>
Status	Closed. HBRO only.	TBA = To be advised.
GoC	Jim Taylor	(which means I don't know yet.)
Steward	TBA.	
Chief Marshal	Roger Hardwick.	
Scrutineer	Trevor Jones.	
Sec of Meeting.	Brenda Taylor.	
Camping	n/a.	
Scrutineering starts at	08:45.	The venue is on the A325, a couple of miles south of the roundabout with the A31.
Drivers / NAV'S briefing	09:45.	The event is open to all fully paid-up members of HBRO.
Marshals briefing	09:45.	
Event starts at	10:00.	
Payment to Sec of meeting.		
£12 on the day. £10 advance (>7 days).		Please read the Competition Event Information inside back cover.

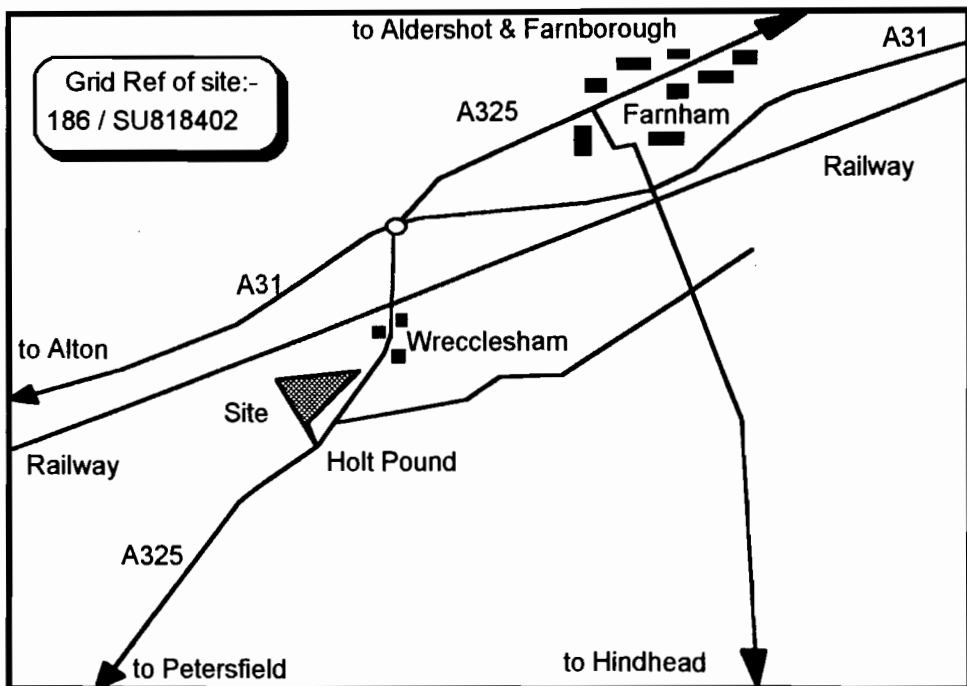

## Harroway Farm RTV Report

With all the foul weather we've had lately, it looked as if the Harroway trial may not happen. Luckily the rain had been less severe in the preceding days, so we were able to go ahead as planned.

During setting out on Saturday it became obvious that parts of the area were going to be no go. Once again it was mighty cold but large amounts of rushing about helped keep us warm. Kiran Raval was in charge of proceedings for the weekend and was able to test all the sections in his Discovery along with Ian Parker in his S11.

Early in the day the ground was frozen and fairly grippy, but as it thawed out the mud came into play and grippy turned to slippery making even standing up tricky. Even so the team managed to build a course that was fun.

On Sunday morning it was great to see 16 competitors sign up to trial, 2 of them being new members; Gordon Kerr from Lightwater and Terry White from Bournemouth.

We all managed to slip and slide our way around the sections as best we could and had a real laugh doing so. The series motors had the advantage on the day, so it seems by the scores. I imagine the combination of light weight and slippery slopes go together well. Paul Homewood showed us all how it should be done with a final score of 16, which, given the conditions, was an excellent result.

Results are:

Class 3

Paul Homewood 16    Chris Homewood 24    Matt Hewitt 24.

Class 4

Hugh Duffett 24    Nick VDB 29    Neil Shawyer 35    John Jennings 35

Terry White 37 (First trial)    Mike Wood 41    Simon Newington 44

Adrian Bourne 46    Neil Tomlinson 51    Gordon Kerr DNF (First trial)

Class 5b

Klim Corke 38 (First trial)

Class 8

Steve Skinner 21

Setting Out Officials: Mike Wood, S Skinner, Kiran Raval, Rick Bauer, Ian Parker, John Jennings, Nick Jennings, Andy Bridger, Simon Garrett & Kim Taylor.

Trial Officials: Kiran Raval (COC), Carol Skinner (Secretary), Nigel Thorne (Scrutineer), Sam Parker (Steward), Ian Parker (Chief Marshal)

A special thanks goes to the Marshals who were Sarah & Andy Bridger, Mark Halliday, Bob & Peter Paine who braved the cold all day. Many Thanks!!

Steve Skinner.

# Ten Pin Bowling, Saturday 24<sup>th</sup> February 2001 Spectrum Bowling Guildford

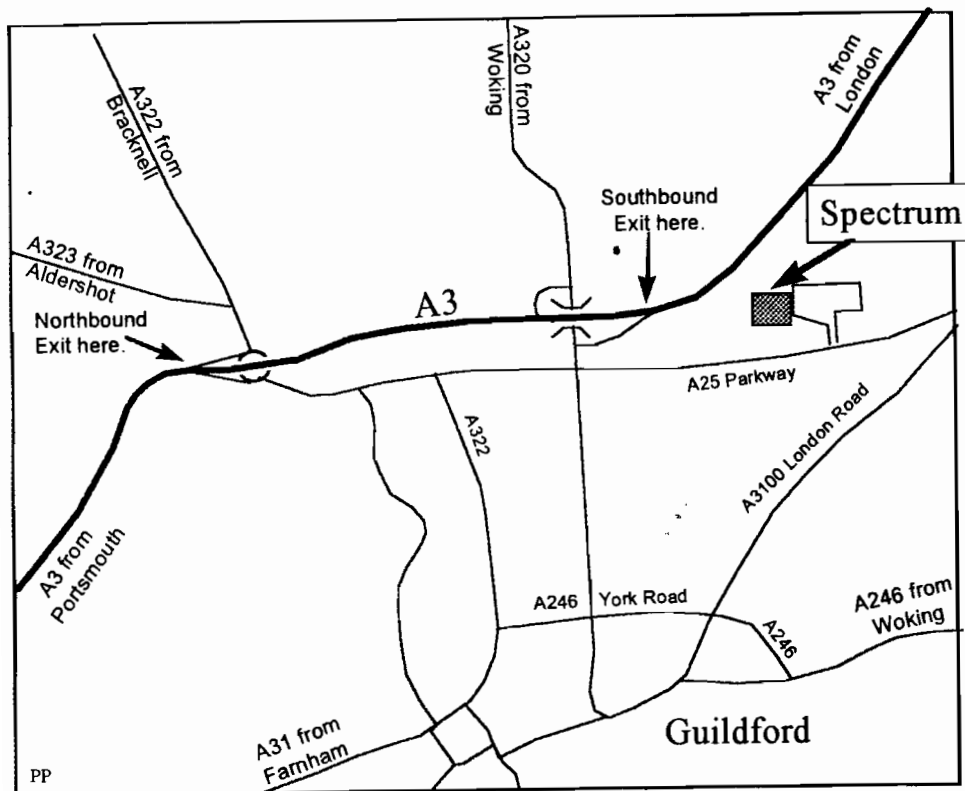

Meet at 7.30pm for 8.00 start. The cost will be £8.10\* per person. This covers 2 games and shoe hire. Food is also available at the bowling alley if required.

Please book your place with Sam Parker. Complete the booking form with a cheque made payable to 'HBRO'.  
(\* Last year's price; This year's price not checked at time of going to press.)

## Bowling Booking Form

Name:..... Tel No.....

No of places:..... Total Enclosed:.....

Please phone Sam Parker Tel: 023-9263-9193 Mobile: 0802-346743 to check that it's on. Sam will advise on price too.



## The Land Rover marque Day at the Heritage Motor Centre, incorporating "The Heritage Motor Centre Run" Sunday 6<sup>th</sup> May 2001

In 2001, this now well established event in the Land Rover scene reverts to its more usual date of the Sunday preceding the May Bank Holiday Monday.

Bob Dover, a confirmed classic car enthusiast, who is the newly appointed Chief Executive Officer of LAND ROVER and chairman of the British Motor Industry Heritage Trust, is looking forward with enthusiasm to this event.

Entry into this year's HMC run costs £10 per vehicle. This includes free entry to both the event and the museum for the driver and one passenger, plus a Rally Plate for the vehicle; a Limited Edition Rally Plaque and "fast track" entry into the Centre on Sunday. Additional passengers in Cavalcade vehicles should pre-book their entry tickets - at discounted rates of £5 (adult) or £3 (child 5 yrs - 16 yrs) - with their Cavalcade entry.

Entry forms may be downloaded from the ARC website at [www.the-arc.co.uk](http://www.the-arc.co.uk) or by requesting "the genuine article" from Chris Savidge (Snr) on 0115-9267716.

For non-cavalcade participants attending THE LAND ROVER MARQUE DAY at HMC in a Land Rover product, the following entry conditions have been arranged. The driver gets free entry, but all passengers must pay the discounted admission rates (as above) at the pay booths. It is best to arrive well before 11:00 am, in order to witness the arrival of the 1500-vehicle cavalcade from Solihull - one of the highlights of the MARQUE DAY.

In addition, there are to be superb displays by the LAND ROVER COMPANY. Remember, this is the first time that this event has taken place with HMC under the ownership of LAND ROVER! We are also looking forward to club stands, trade and auto-jumble stands, possible Land Rover dealer support, "Land Rover Gear" on sale in the museum shop - together with the latter's normal comprehensive range of models, books and much more! The usual family and children's entertainments will also be there.

Basic camping and caravanning will be available for Saturday, Sunday and Monday nights (5<sup>th</sup>, 6<sup>th</sup> and 7<sup>th</sup> May) on the meadow within the Centre's grounds. Full details and costs are on the entry form.

For booking either clubs, trade or auto-jumble stands for the LAND ROVER MARQUE DAY, please contact Jane Roche, HMC's events manager, on 01926-645120 or fax 01926-641555, or e-mail her at [janer@heritagemotorcentre.org.uk](mailto:janer@heritagemotorcentre.org.uk)

## Spanish Trip News

Due to unforeseen circumstances, Steve & Carol Skinner will not now be organising a Spanish off-road trip. We apologise for any inconvenience this may cause.



# **A.R.C. NEWS**

**The Newsletter of the Association of Rover Clubs**

**Issue 39**

**January 2001**

Each edition of ARC NEWS can be found on the **ARC website [www.the-arc.co.uk](http://www.the-arc.co.uk)** If you wish to subscribe to receive a copy by e-mail please log on to [arcnews@tesco.net](mailto:arcnews@tesco.net)

## **RAC COVER**

**To All Members of RAC Motoring Services and Associate Clubs.**

Please read through the article below. It's my opinion of the current situation and your individual circumstances should be checked with RAC Motoring Services. I cannot be responsible for losses or costs should you incur them as the matters below may be the subject of legal action. RAC Motoring Services has withdrawn its cover for vehicles used in Motorsport of any form. This includes Racing, Rallying and mildly competitive events such as Driving Days and Touring Assemblies. This was done by letter dated the 14th August 2000 to all Associate Clubs of RAC Motoring Services, which includes the Royal Automobile Club Motor Sports Association. The letter states that cars, which have broken down or have been involved in an accident in an event that does not follow the normal rules of the road, are no longer covered by the RAC. This includes mildly competitive events such as Driving Days and Touring Assemblies. It also goes on to say that no commission will be paid to the majority of Associate Clubs. These benefits have been in place since the setting up of the Associate Section in 1907. In the latest Motorsports Now! there is an article stating that the service has not been withdrawn. This was written and published by the MSA who now have agreed that their content IS WRONG. The incorrect information in the article was also circulated to the Regional Associations of Motor Clubs. At a meeting yesterday (4/12/2000) with the RAC Motoring Services manager responsible for pushing through the changes, I have put it quite clearly to him that these changes must be made clear to individual members, which they have not been. Any member who is in receipt of the latest 'Terms and Conditions' will find no exclusions for Motorsport. The RAC cannot, according to its own 'Terms and Conditions' and possibly the law make such changes without informing the member at renewal time. Thus members who have renewed in the last year are still covered for Motorsport. Until such time that the terms and conditions are amended and sent out to new and renewing members, pointing out the changes, RAC Motoring Services will have to honour their terms and conditions, for the period of the membership. I await a formal response from the RAC Motoring Services about this and draw your attention to the disclaimer in my first paragraph. I will continue to lobby on behalf of competitors for the rights of membership that have existed since 1907. I have constantly pointed out that the enthusiast member is that least likely to call out the RAC, the majority of call out is for minor problems that would be sorted out

or ignored by the clubman. In the major events, such as stage rallies, competitors have service crews and trailers and it is the person who takes part in a mildly competitive event that will suffer. This will prompt the majority of clubmen to look elsewhere for their breakdown cover. I have suggested that the RAC should restrict its cover to vehicles, which display a valid Vehicle Excise License (Tax Disc). That way cars which are road legal only are covered and there would be no ambiguity or enquiries as to the use of the vehicle. This definition has been agreed verbally with the MSA and follows the practice of another major breakdown service. The condition of service for reasonable access to get to the vehicle would remain. A separate issue remains over the withdrawal of commission payments to the majority of motor clubs. I would like to hear from individuals and clubs who have or will be affected by these changes. I would advise individual members and clubs to seek their own clarification until such time as RAC Motoring Services has written to members individually. I have, of course, pointed out to RAC Motoring Services, that we have a choice. Mike Hurst, Treasurer, Middlesex County Automobile Club Ltd. Founded 1905 and associated with the RAC since that date. Member, RAC Motoring Services, Specialist Motor Group PS, for those of you who don't know me, I was a member of the RAC Associate Committee, elected by Motor Club representatives attending the General Council of the RAC held yearly at Pall Mall. As such I will continue to seek and represent the views of Clubs and Members alike to the new organisation.

## **NON-COMPETITIVE CLUB NEWS FROM CHRIS SAVIDGE (SNR)**

### **Change to "Most Original Working Vehicle Class"**

At a recent meeting of the non-competitive sub-committee, it was agreed to place a "cut-off" date for the age of vehicles eligible to enter this class at the International Rally. This has, initially, been set for 1983-the intention being to make the date the end of the leaf sprung era - so the date of 1.3.83 when Land Rover 110 production started has been selected as appropriate. This change is intended to exclude entry of very new vehicles, which obviously would have a far greater chance of being completely original! This "cut-off" date will be reviewed after the 2001 International. Cornwall and Devon Land Rover Club will be running both the Concours and Working Vehicles classes at Newnham Park this year, with the assistance of THE SERIES ONE CLUB, and the sponsorship of the local franchised Land Rover Dealer. Rover cars are very welcome at this event - the forecourt of Newnham House will provide an excellent venue for them. C&D LRC is working hard to provide a "spectator-friendly" event, with much to interest all categories of A.R.C.'s membership. Book in with Jean French on 01752-338279.

### **European Parliament Legislation**

I have heard, via Tony Holder of A.R.C. and R.S.R., that the END OF LIFE (VEHICLES) DIRECTIVE has at long last, become a European Directive which sets out in detail the obligations and procedures to be adopted by Member States for dealing with "life-expired" vehicles. Historic vehicles - a definition which includes vehicles of value to collectors - are excluded from the Directive. They are also formally recognized as NOT being "waste" and as such fall outside the scope

of all European Waste legislation. All that remains to be done now is to carefully monitor how each Member State enacts this Directive into their own system so as to ensure that exemption for historic vehicles is not lost along the way!

All credit must go to the International Historic Vehicle Organisation for recognizing the potential dangers in the original draft of the Directive and alerting other historic vehicle organizations throughout Europe so that everyone could work together to ensure that the interests of historic vehicle enthusiasts were protected.

#### **New Clubs join A.R.C. Member Clubs**

At the December EGM two new clubs gained the approval of the delegates present to become A.R.C. Member Clubs. These are The Vectis Land Rover Club based on the Isle of Wight and the Discovery Owners Club – which is a national single marque club. Both clubs are non-competitive.

#### **Advance notice of the 2001 "All Rover Weekend"**

The 2001 ALL-ROVER WEEKEND will take place on August 25<sup>th</sup> –27<sup>th</sup> at the "Town and Country Festival" at Stoneleigh Park, near Coventry. This is definitely an event to suit all tastes – you simply cannot be bored at the T&C, only weary from trying to see all of it!

This year sees a new member joining the "established" team, (myself and Bonny my wife and Sue and Ian Foster of the lightweight Land Rover Club) in the person of Mike Page of the Range Rover Register. Mike's particular responsibility will be to book you all in, either as day visitors or camping/caravanning – in either Land Rover products or Rover Cars. The latter are especially welcome at the All Rover Weekend.

#### **A new "M.D." for Heritage Motor Centre**

On Tuesday, 2<sup>nd</sup> January, the newly appointed Managing Director of the Heritage Motor Centre was introduced to Centre staff by Gavin Green, Director of Communication and Public Affairs – LAND ROVER.

The new M.D. is Julie Tew, who will take up her new position at Gaydon in March 2001.

The previous M.D. Fred Coultas, retired in April 2000. Since Fred's retirement, Peter Mitchell has been acting M.D. of Heritage Motor Centre. Peter was Chairman of British Motor Industry Heritage Trust until November of last year, when he was succeeded in the latter post by Bob Dover, Chairman and Chief Executive Officer of LAND ROVER.

#### **Finally a "thank-you"**

Bonny would like to thank all those of you who have sent us Christmas and New Year greetings. We are sorry, but we cannot hope to reply individually. Our best wishes for a fulfilling year in 2001 to all members of A.R.C. Clubs.

Chris Savidge (Snr) Non- Competitive Clubs Co-ordinator

## THE LAND ROVER MARQUE DAY INCORPORATING THE HERITAGE MOTOR CENTRE RUN TO BE HELD AT THE HERITAGE MOTOR CENTRE, GAYDON, 6th MAY 2001

In 2001, this now well-established event in the Land Rover club scene, reverts to its more usual date of the Sunday preceding the May Day Bank Holiday Monday.

Bob Dover, Chief Executive Officer of Land Rover, and newly appointed Chairman of The British Motor Heritage Trust, is a confirmed classic car enthusiast, and is looking forward with enthusiasm to this event.

Entry into this year's HMC Run costs £10 per vehicle. This includes entry to both the event, and the Museum, for the driver and one passenger, plus a rally plate for the vehicle; a limited edition rally plaque, and "fast track" entry into the Centre on the Sunday. Additional passengers in Run vehicles should pre-book their entry tickets with their Run entry, at discounted rates of £5 per person, (children up to 16yrs F.O.C.). Entry forms may be downloaded from the **ARC website at: [www.the-arc.co.uk](http://www.the-arc.co.uk)** or by requesting the genuine article (non electronic !) from **Chris Savidge (Snr.) on 0115 926 7716.**

For non-Run participants attending the Land Rover Marque Day in a Land Rover product, the driver will get free entry, but all passengers must pay the discounted admission rates of £5 per adult, £3 per child (5yrs to 16yrs), at the pay booths. It is best to arrive before 11.00 am, in order to witness the arrival of the 150-vehicle cavalcade from Solihull - one of the highlights of the day.

In addition, there are to be superb displays by the Land Rover Company. This is, of course, the first time that this event has taken place with HMC under Land Rover ownership.

We are also looking forward to Club Stands, Trade and Autojumble stands, possible Land Rover Dealer support, and Land Rover 'Gear' on sale in the HMC shop together with their normal comprehensive range of models, books, and memorabilia. The usual family and children's entertainments will also be there.

Basic camping and caravanning will be available for Saturday, Sunday, and Monday nights (5th, 6th, 7th May) in the meadow within the HMC grounds. The site will open at 10.00am on Saturday and will close at noon on Tuesday.

Fees for camping/ caravanning will be £10 per night per unit, which covers two adults per unit for camping, and admission to the Museum and all other HMC normal facilities. Extra persons will need pre booked entry tickets at £5 per night per adult, £3 per night per child (5yrs. to 16yrs). **Please Note**— extra adults paying to camp, do not need to pay again as passengers in the Cavalcade.

Booking forms are available direct from Chris Savidge, or may be downloaded from the ARC website at [www.the-arc.co.uk](http://www.the-arc.co.uk)

For booking either Club, Trade, or Autojumble stands, please contact:  
Jane Roche, HMC's Events Manager, on 01926 645120 or fax 01926 641555,  
or e-mail at [janer@heritagemotorcentre.org.uk](mailto:janer@heritagemotorcentre.org.uk)

**Booking form at the end of this Newsletter**

**EVENTS**

**DUNSFOLD LAND ROVER SPRING SALE 7<sup>th</sup>/8<sup>th</sup> APRIL 2001**

Hot news for fans of the Series Land Rovers is that Philip Bashall is again organising a sales weekend at Dunsfold. Ample parking will be available on the adjacent field. As always Philip will also have a huge pile of second hand parts for all models.

**THE MAJORS MEMORIAL TRIAL 2001 – MIDLAND ROC**

Midland ROC are pleased to announce that they have secured agreement with Eastnor once again for the Majors Memorial Trial to take place at Eastnor. The date of the event is the weekend of 7<sup>th</sup>/8<sup>th</sup>/9<sup>th</sup> September 2001. MROC will issue an invitation, event information and booking forms in due course to Member competitive clubs.

**LANGLEY FARM – YORKSHIRE ROVER OWNERS CLUB**

Once again YROC are please to host the annual Langley Farm event over the weekend of 8<sup>th</sup>/9<sup>th</sup> September 2001 –again booking details in due course.

**THE A.R.C. GREEN BOOK**

The A.R.C. Council wish to remind all members that the Green Book will not be issued for 2001 instead, the 2000 edition will continue until the next edition is produced, this has been agreed in order to save Members and Member clubs money.

As a result it is necessary to issue a series of amendments to bring your 2000 edition up to date.

Steve Kirby has kindly put together the following;

**Corrections and amendments to the ARC 2000 Handbook.**

**The following can be cut out or photocopied and stuck inside the front cover of your 2000 Year Book.**

**ARC Council & Executive Committee 2000 - 2001**

(C) Chairman	Denis Bourne, 124 Crescent Drive, Petts Wood, Orpington, Kent, BR5 1BE, 01689-839458. E-mail <a href="mailto:1tonne@orpington101.freeserve.co.uk">1tonne@orpington101.freeserve.co.uk</a>	Shows & Displays Co-ordinator	June & Jack Green, 'Arncof', 13 Stewartsfield, Rowlands Gill, Tyne & Wear, NE39 1PF. 01207-545448.
(C) Vice Chairman	Harold Carman, 86 Moughland Lane, Runcom, Cheshire, WA7 4SQ, 01928-564388 E-mail <a href="mailto:g-carman@email.msn.com">g-carman@email.msn.com</a>	CCMSA Co-ordinator	Andrew Neaves, 8 Easthouse Drive, Hurley, Nr. Atherstone, Warwickshire, CV9 2HB, 01827-874008. E-mail <a href="mailto:Andrew.Neaves@bt.com">Andrew.Neaves@bt.com</a>
(C) Secretary	Caroline Flanders, PO Box 363, Berkhempstead HP4 3FR Tel 01442-873567. E-mail <a href="mailto:arc-sec@ledburn253.freeserve.co.uk">arc-sec@ledburn253.freeserve.co.uk</a>	(C) Non-Competitive Clubs Co-ordinator.	Chris Savidge, Wicketwood House, 86 Spring Lane, Lambley, Nottingham. NG4 4PG 0115-926-7716.
(C) Treasurer	Andrew Stavordale, 48 Shearwater Road, Offerton, Stockport, Cheshire. SK2 5UJ Tel: 0161-292-5740 e-mail <a href="mailto:Stavors@aol.com">Stavors@aol.com</a>	(C) Car Clubs Liaison	Situation Vacant.
(C) Caravan Secretary	Chris Hodson, 43 Chequers Drive, Horley, SURREY. RH6 8DX 01293-786144	(C) Council Member without Portfolio	Colin Council, 73 Westmeads Road, Whitstable, KENT CT5 1LW 01227-771107 <a href="mailto:colincouncil@hotmail.com">colincouncil@hotmail.com</a>
(C) International Liaison Officer	Derek Spooner, Banks Cottage, Abbots Morton, Worcester, WR7 4NA. 01386-792767.	(C) Council Member without Portfolio	Tony Holder, Blue Fir, Bellingdon, Chesham, Buckinghamshire, HP5 2XW 01494-783437. E-mail <a href="mailto:Tony.Holder@classicfm.net">Tony.Holder@classicfm.net</a>
(C) Countryside Access Officer	Tony Kempster, Knelle Hill Lodge, Beckley, Rye, East Sussex, TN31 6UD, 01797-252371.	Scrutineering and Off-Road Committee	(Chairman) (C) Steve Kirby, 244 Staines Road, Twickenham, Middlesex, TW2 5AR, 020-8287-0377. E-mail <a href="mailto:Steve.Kirby@cwcom.net">Steve.Kirby@cwcom.net</a>
(C) National Rally Liaison Officer	Norman Whiteley, 10 Thorncliffe, Kirkburton, Huddersfield, West Yorks., HD8 0UG 01484-603564. E-mail <a href="mailto:norman@maysand.co.uk">norman@maysand.co.uk</a> .		(Vice-Chairman) Harold Carman, 86 Moughland Lane, Runcom, Cheshire, WA7 4SQ, 01928-564388. E-mail <a href="mailto:g-carman@email.msn.com">g-carman@email.msn.com</a>
(C) Press & Publicity Officer	Nick Chinery, 11 Main Street, Broughton Astley, Leicester. LE9 6RE Tel 01455 285304. E-mail <a href="mailto:nrick@x-stream.co.uk">nrick@x-stream.co.uk</a>		(Logbook Sec'y) Dennis Wright, 14 Dale Close, Skegby, Sutton-in-Ashfield, Notts, NG17 3AF, 01623-515393. E-mail <a href="mailto:PEAKCHAIR@aol.com">PEAKCHAIR@aol.com</a>
ARC News Editor	Paul Barton, 26 Summerhill Grange, Summerhill Lane, Lindfield, Haywards Heath, West Sussex. RH16 1RQ 01444 452120 e-mail: <a href="mailto:PaulBarton.home@ukgateway.net">PaulBarton.home@ukgateway.net</a>		John Hewitson, 2 Offin Close, Sandwell Valley, West Bromwich, B70 6TA. 0121-553-1547.
ARC Handbook Ed.	Steve Kirby. Address opposite.		Colin Parry, 94 Parc-y-Dre, Ruthin, Clwyd. LL15 1PH 01824-705320.
Rover Company Liaison.	Situation Vacant.		Mick Gillet, 65 The Straits, Lower Gornal, Dudley, West Midlands, DY3 3AL, 01902-884407.
Technical Officer	Ken Knight, Bird Lymes Cottage, Porton, Salisbury, Wiltshire, 01980-610776.		Ray Sykes, 5, The Mains, Beetham, Milnthorpe, Cumbria, LA7 7AS, 015395-62074.
Minutes Secretary	Sandra Bourne.		Dennis Bown, 34 Elvaston Road, North Wingfield, Chesterfield, Derbyshire, S42 5HH 01246-865960.
(C) MSA Liaison	Harold Carman, 86 Moughland Lane, Runcom, Cheshire, WA7 4SQ, 01928-564388. E-mail <a href="mailto:g-carman@email.msn.com">g-carman@email.msn.com</a>		Adam Pinder, 64 Church Lane, North Wingfield, Chesterfield, Derbyshire, S42 5HSQ, 01246-854043

(C) = Council Member.

Page 2, opposite contents, add registered address of the ARC:-  
Association of Rover Clubs Ltd. Limited by guarantee. Registered in England No. 1806788  
Registered Office:- 124 Crescent Drive, Petts Wood, Nr Orpington, KENT, BR5 1BE

Page 18. Caravan Secretary, Chris Hodson, address is now 43 Chequers Drive, Horley, Surrey, RH6 8DX 01293-786144

Page 23 item 3, change " Jim Campbell " to " Chris Hodson " His address is now 43 Chequers Drive, Horley, Surrey, RH6 8DX 01293-786144

Page 33\* - Tow ropes and recovery. Change " \_ " to " ¼ " "

Page 49. Vehicle Regulations - Rule D.4.3. omitted in error (This is effective already):-  
**D.4.3. In special circumstances, for certain events, rules D.4.1. and D.4.2. above may be superseded with the approval of the ARC Council with reference to regulation H.25.1.1. in the MSA Yearbook.**

Page 50. Renumber E.10. to be E.9.

Page 86\* at the very bottom change " fi " to " ¼ " "

Page 92\* Q.7.6.4. change " 1 > " to " 1½ " two places.

Page 97\* Q.8.3. change " f " to " ¼ " "

\* Printing error.

Page 114 add LAND ROVER REGISTER 1949 - 1953 SHIELD for Highest placed Land Rover in this date range.

Rule changes - effective 1-1-2001

Page 43. Add definition to the Vehicle Regulations preamble in the Handbook:-

"Where factory fitted" as quoted in various places in the rules is intended to mean that the item was fitted to that type of vehicle in the course of manufacture by Land Rover Ltd. or any company contracted by Land Rover to build / assemble their vehicles.

Page 43/44. Revised wording for A.2.1. Class 11.

## A2 VEHICLE CLASSES

A.2.1. Trials:-

**Class 11. Special Long Wheel Base. Leaf sprung.**

Page 44. Revised wording for A.7.:-

## A.7. WHEELS.

A.7.1. Road wheels shall be of steel construction, have a rim diameter of 15" or 16" and other sizes where factory fitted and not have an offset between the outer flat of the nave plate to the outer flange of the rim of more than 100mm.. All Land Rover, Range Rover and Discovery steel wheels comply with this regulation.

Page 45. Revised wording for A.12.:-

## A.12. SILHOUETTE.

(Note:- The "body capping line" on a Land Rover is defined as a horizontal line level with the top edge of the fixed rear load area surround. The "window line" on a Range Rover and Discovery is level with the bottom edge of the side windows. There should be a capping to present a "safe edge". Many vehicles with non-original panels terminate in a cut edge on the periphery of the load-area. Either a turned over top edge to the load area or an actual capping strip, not necessarily a Rover original, is required. If the tailgate is removed, then any capping that is normally part of the tail-gate will be removed too.)

Page 48. Revised wording for B.4.1.:-

B.4.1. The handbrake must operate on the transmission only unless factory fitted.

Page 48. Revised wording for C.2.4.

C.2.4. The following are prohibited: - Forced induction petrol engines; slide throttles; the inhibition of the firing of one or more cylinders to gain advantage'.

Page 52. Revised wording for H.5.:-

**H.5. SHUNTS. Vehicles over 95" wheelbase are allowed one reverse (shunt) per section which can be taken at the driver's discretion after receiving marshal's consent but BEFORE coming to an involuntary halt; unless stated otherwise in the SRs.**

## ARC MEMBER CLUB EVENTS

**SOUTHERN ROVER OWNERS CLUB CHARITY COMPETITIVE SAFARI, MEREWORTH WOODS NR. MAIDSTONE - Sunday 21 JANUARY 2001**

As we go to press, there is still some entry space left. Booking forms for this event are now available from Debby Darby, 54 Northwood Road, Tankerton, Whitstable, Kent CT5 2ES. Event open to all A.R.C. Clubs, Entry £20. Clerk of the Course is Tony Howland and the grid reference is 188 643 554. Be Quick!!

## FUTURE EVENTS CALENDAR

### MAY 2001

5<sup>th</sup>/6<sup>th</sup> Y Rali Bryn Cymru - Hillrally  
6<sup>th</sup> - Land Rover Marque Day/Heritage Motor Centre Run  
11<sup>th</sup> - 13<sup>th</sup> Land Rover World Show  
19<sup>th</sup> - 20<sup>th</sup> Land Rover Owners Show  
25<sup>th</sup> - 29<sup>th</sup> May A.R.C. INTERNATIONAL 2001 Newnham Park Plymouth C&D LRC

### JUNE 2001

GKN Driveline Scottish Hillrally

### JULY 2001

20<sup>th</sup> - 22<sup>nd</sup> Billing 2001 Land Rover Enthusiast Show

### SEPTEMBER 2001

9<sup>th</sup>/10<sup>th</sup> September Langley Farm - Yorkshire ROC - details to follow

### OCTOBER 2001

October 5<sup>th</sup>/6<sup>th</sup>/7<sup>th</sup> The Hillrally

### OTHER NON A.R.C. EVENTS

#### MACMILLIAN 4x4 UK CHALLENGE

I would like to bring your attention to a Charity event that I and a few other members of Chiltem Vale ROC will be taking part in next March. It is not an ARC event and will involve vehicles other than Land Rovers but clearly it would be nice to see a Landie come home with the silverware, also it is in aid of a very good cause. Entry fee is £100 per team of 2 + each team needs to gain a further £400 in sponsorship for the Macmillan Cancer Relief Fund. If any of you or any of your members would like to put a team forward either contact Peter Rowland on 01886 832320 or visit <http://members.aol.com/TelemationLtd/Macmillan/> as soon as possible. There is a maximum entry of 50 teams. *Russ Brown*

IMPORTANT - Participation at any competitive event or show is at your own risk or that of the organisers. Although the A.R.C. is happy to publicise such events it does not act as an agent for the organisers. Statements or opinions expressed in A.R.C. News are not necessarily those of the A.R.C. Council. You are advised to obtain independent advice on matters involving safety, finance or legislation.

This Newsletter is compiled and edited by Paul Barton, ARC Newsletter Editor, for the Association of Rover Clubs

Contact Editor at 26 Summerhill Grange, Summerhill Lane, Lindfield, Haywards Heath, West Sussex, RH16 1RQ

e-mail: [PaulBarton.home@ukgateway.net](mailto:PaulBarton.home@ukgateway.net)

ARC Secretary: Caroline Flanders, tel/fax: 01689 878105

Association of Rover Clubs Ltd. Limited by Guarantee Registered in England No. 1806788  
Registered Office, 124 Crescent Drive, Petts Wood, Orpington, Kent BR5 1BE

SOUTH COAST SAFARIS

# Want to drive off road?

Experience driving a fully expedition Prepared land rover or your own 4x4 on one of our exciting off road courses.

suitable for all 4x4s.

gift vouchers available

## Adventure Holidays

exciting 4x4 adventure holidays on the picturesque

greek island of rhodes

as seen on meridian tv

for more information or brochures, please contact :

south coast safaris  
(023) 8045 5349

or e-mail - [Safaris@btinternet.com](mailto:Safaris@btinternet.com)



## Hants and Berks Club Shop

### T Shirts – Adults

LR Display	Navy	£ 8.00
Embroidered Shield	All Colours	£10.00

### T Shirts – Childrens

LR Display	Navy	£ 6.00
Embroidered Shield	All Colours	£ 8.00

### Sweatshirts – Adults

LR Display	Navy	£20.00
Embroidered Shield	All Colours	£23.00

### Sweatshirts with Collar

Embroidered Shield	Grey, Navy, Green	£26.00
--------------------	-------------------	--------

### Polo Shirts – Adults Short Sleeve

Embroidered Shield	All Colours	£16.00
--------------------	-------------	--------

### Polo Shirts – Childrens Short Sleeve

Embroidered Shield	All Colours	£12.00
--------------------	-------------	--------

### Rugby Shirts – Long Sleeve

Embroidered Shield	Black, Navy, Burgundy	£30.00
--------------------	-----------------------	--------

### Rugby Shirts – Short Sleeve

Embroidered Shield	Black, Navy, Burgundy	£25.00
--------------------	-----------------------	--------

### Fleeces

Adults Half Zip	Black, Navy, Green	£28.00
Adults Full Zip	Black, Navy, Green	£31.00

\* \* \* \* \*

<b>Size Guide:</b>	Small – 36in Chest	Medium – 38-40in Chest
	Large – 42-44in Chest	X Large – 46in Chest

**PLEASE NOTE:** All clothing is order only and must be accompanied by full payment.  
Order may take up to two weeks.

CHEQUES MADE PAYABLE TO "HANTS & BERKS ROVER OWNERS"

Send orders to Sarah Bridger, HBRO Club Shop, Address inside front cover.

# ONE SYSTEM

# ONE ANSWER

**'open business solution'**

low Cost

highly tailorable

easy to use

**'At last, one piece of software to handle all your business  
and financial requirements'**

**Open Door Software Ltd 020 7538 0505**

**E-mail: [info@open-door.co.uk](mailto:info@open-door.co.uk)**



www.

# Greaves 4x4.co.uk

JUL00

Specialist in 4x4 preparation, Pre and Post event checks, Maintenance and servicing of all 4 wheel drive vehicles.

Visit our Website to see what we can do for your 4x4  
<http://www.greaves4x4.co.uk>

e-mail: [peter@greaves4x4.co.uk](mailto:peter@greaves4x4.co.uk)

Or Just Call 0118 934 1010 (mobile) 07966 156402

Unit 3a, Phoenix Park, Nelsons Lane, Hurst, Berks, RG10 0RR.

## F & R Commercials

### L Rover R Rover Discovery

S 1, S 2, S3, 90, 110

RR & DISCO

*Repairs and Servicing*  
OVER  
25 YEARS  
EXPERIENCE

**Affordable Rates**

**Quality Preparation  
and Welding to MOT  
Standards**

01329 832364 Restorations - come and discuss

**Borderside, Southwick Road, Wickham**

2 miles North up A32 from M27 junc 10 west-bound  
then 1 mile East from Wickham Church

FEB01

## For Sale

Note that small ads are free but please let the editor know when a sale is complete so we don't keep printing an out of date ad each month. I know I forget sometimes so you may need to remind me more than once! Please help potential customers by quoting location (nearest large well-known town), phone number with full national dialling code, fax, e-mail, etc in your adverts. All the following adverts are dated as to their first month of publication. When they become about 3 months old, they will be deleted unless the "owners" renew them! Please don't just leave an old advert to "time-out", Thanx.

HBRO accepts no liability for the accuracy of the descriptions or the serviceability / suitability of items sold in this section.

Commercial Adverts:- Contact Zoe Raval, address inside front cover, for advertising rates. Current newsletter circulation is over 300. Adverts are marked with the start date so you know when their time is up!

## Bits & pieces

\* Hard top for Defender 90 (ribbed), with side windows and back door (back door is in not too good condition unfortunately). £200. Chris Minassian. Home 01252 834119, Mobile 0799 052 1039 or email at [keek@btinternet.com](mailto:keek@btinternet.com) (FEB01)

\* Twin axle car transporter trailer. 2.5 ton capacity. Professionally built 1992. Fully decked. Ramps, Lights & Brakes all in excellent condition. Fully under-sealed. Will carry a R/R or LWB Land Rover. £750 ono Richard Myers on 023-8045-5349, 07790-827405 or [R.Myers@btinternet.com](mailto:R.Myers@btinternet.com) (DEC00)

\* I'm going Automatic, so I have (or will have !) the following parts for sale :- Range Rover LT95 4 Speed Gearbox WITH 101 Short bellhousing fitted, currently in my hybrid so you can even drive it to see how good it is !!, only £350, Also my Range Rover Overdrive, again on my hybrid, and the linkage has been modified (look, nothing is standard on my bloody L/R!!), so that it has less slop and different position (nearer Gear Lever), again can be tested prior to purchase, yours for £350, Also a very expensive Ceramic Clutch with Stainless steel release unit will fit any R/R and will handle over 300 BHP - Fit and forget it, it cost me a absolute fortune, yours complete for £125 ish, - (hard to by standard stuff for that money - this will last forever, the hotter the unit gets the harder clutch grips - you will never burn it out or get clutch slip !!. and Late VGC V8 Flywheel £25. Then there's my spare LT95 4 Speed unit - VVVG condition (had a fortune spent on a rebuild), I promise you it will be better than you ever think it could be; yours for £250. Shortly to be available my Superwinch 9 winch all complete, now on the front of my Hybrid, (suppose it could be tested!), yours for probably about £450-ish, and fitting, or mounting can be made, helped with, or done!

Also a complete and rather rare Fairey Mechanical PTO driven winch system, very powerful, which will fit any Series 1 / 2 / 3 SWB or LWB (minor mods excluding!), complete with the original unbent VERY heavy duty bumper system (see LRE Issue 1 Page 80 Top Right for a pic!), yours for around £400, and fitting can either be done or helped with, if you have a series L/R and want a proper H/D Winch this is the kiddy to fit!!

Thought it was sold - but apparently not! - Series 1 prob 49/50 Narrow sprunged 80 Inch Chassis GC no Rot, no V5 etc as was a trialer £150, Compact Space heater (Propane) very powerful, virtually new with bottle £125, or cheaper a Superser mobile Calor Heater (with Bottle). Winter's coming stay warm for £40. Series 1 86inch windscreen with glass GC £40, Series 3 Bulkhead - not too bad needs footwells maybe £30 or skip time shortly! 240v Air compressor, not old with hose and some attachments, will drive most equipment including spray gun etc £125 ono, Loads of "Lin Bins" of various sizes and wall plates - get organised!! Ring for details, Loads of R/R early and late axle parts, Clarke metal cutting bandsaw all complete and working £100 ono, 3.9 Twin exhaust manifolds £35 Pair, 3.5V8 Single exit manifolds, Pair £35, Series 11A Gearbox no probs £125, that's all for now !!!!!

Phone call me on 07909-973163 anytime, or Home on 01428-653795 before 8.30pm PLEASE ! or e-mail me on nigel.barker@ukgateway.net (DEC00)

- \* Discovery roof-mountable lockable luggage box complete with mounting rails. Only used once - impeccable condition. £150.00 (cost £500.00 new). Wokingham area. Contact: Denise Ware - 01189-732532 or 07879-618668 or e.mail at wareru@mcmail.com (NOV00)
- \* 7.50R16 tyres - 2 Michelin XZY (part worn, mileage unknown) and 2 Tygor (almost new). Tyres suitable for on road use and gentle green laning (although they also managed Slab Common a few months ago!) £30 the lot ono. Bug Wrightson (07778) 935010 (Hayling Island). bug@sidz.fsnet.co.uk (NOV00)

## Vehicles for Sale

- \* 88" tax exempt Hybrid. Series 2a body with 90 front end. Coils & discs all round. Southdown underbody protection. V8 & RR box. Valuable registration (WOA 7J). Full soft top. Truck cab & full hardtop also included. swingaway wheel carrier. Custom built stainless exhaust. Long MoT. Recent major service & good seeing to!. Brand new inboard fuel tank with external filler.Rear bench seats. Starts & runs perfectly. £2500 or £3000 with trailer. Richard Myers 023 8045 5349 or 07790 827405 or R.Myers@btinternet.com (FEB01)
- \* Series IIA, 2¼ petrol, SWB 88", safari top. J Reg Tax Exempt. £800 Chris Minassian. Home 01252 834119, Mobile 0799 052 1039 or email at keek@btinternet.com (FEB01)

- \* Land Rover 90. C reg. Hard top with windows. NA Diesel. Blue. Power steering. New tank and tyres. MOT to Jan 2002. VGC. £2750 ono. Phil Smith. Camberley. 01276-26874. (FEB01)
- \* Assorted vehicles: Two ex-military 110s. As is £2200 each. With registration and MoTs £2500 each. Land Rover Series 2. MOT till March 2001. Tax exempt. New tilt. New springs. New cylinder head. Nice little motor, £950 ovno. Call Bob Perfect on 01420-475303 or mobile 07799-673498. (JAN01)
- \* Range Rover 1983. 4 door 3.5V8 manual. 140k. Recent engine rebuild 20k ago. Factory fitted Air conditioning. Complete with a nearly new spare set of town/country types on original rims. A few bruises and bumps but a very good runner. £1750 ono. Call Ed Ellis in Waterlooville on: 02392 268114, email angela.ellis3@virgin.net or edward\_ellis@thsrc.com.tw (JAN01)
- \* Genuine LR90 V8 CSW (County Station Wagon). A Very rare opportunity! 1986 'C' 3.5 V8. 5-Speed, White, Tow Bar, and very very very original! All interior and seats headlining etc are fantastic condition, and it has MOTs going back years and years to prove genuine 90,000 miles. MOT to July 2001, If you want a V8 90 then come and look at this one!! £4250 onvo. Phone Nigel Barker on 01428-653795 before 8.30 pm PLEASE or e-mail Nigel.Barker@ukgateway.net (JAN01)
- \* Defender 90. Hard Top. 2¼ Petrol.1984 Genuine 44k. MOT end Jan 2001. Might need rear cross member next MOT. Very good runner, £1700 ono. Tel. John Allan (evenings only) 01489 790982 (DEC00)
- \* Discovery V8 5.5. Twin carb. 1989 (G). 125k miles. Ex-WAC plate Lode Lane demonstrator (re-registered). Very good condition and very original. Metallic burgundy paint. 3 doors. 7 seats. Twin sunroofs. Electric windows.Headlamp washer. 10 CD player. Stainless steel exhaust. Tow pack (inc MOD typo pin socket). Rear step. RR 3-spoke wheels. Load space protector. Recent re-con gearbox. New disks and brakes. New steering arm. Detailed service history and receipts. 6 months MOT (i.e. Feb 01). MOT to May 01. £5000 ono. Call Dave Dumaresq-Lucas in Greatham on 0789-999-4567 or 01420-538325 (eves) or e-mail david.lucas@netmanage.co.uk (NOV00)
- \* Defender 110 CSW. 1989 (F) Retro fitted with 300 Tdi engine, gearbox, etc. Moorland trim. RDS radio / cassette. PAS. Immobiliser. Tow bar and electrics. W & H swing away wheel carrier. Rear work light. Full length galvanised roof rack and ladder. Side checker plate. Wing top and bonnet protectors. Bull bar. Spots. Mantec snorkel. New timing belt. Blue polybush kit. Recent springs, steering damper, tax and MOT. £6750. Call Tony Finn, Brockenhurst, HANTS on 01590-622059 anytime and talk to me or leave a message. (NOV00)

## Wanted:

- \* Range Rover Roof Lining. Mine's gone all droopy (it's probably the cold weather that does it!) If you have one in fair condition that hasn't gone all saggy, please give me a call. Steve Kirby in Twickenham on 020-8287-0377 or e-mail to Steve.Kirby@cwcom.net or Steve.J.Kirby@BritishAirways.com. (JAN01)
- \* Land Rover 80 or 86" Series 1 Soft Top and hoops etc (any Condition) and also 80 or 86" hardtop, please ring Nigel Barker on 07909-973163 or e-mail nigel.barker@ukgateway.net (DEC00)

---

## WARNING

Any adverts dated up to and including NOVEMBER will disappear next month unless you renew them!

---

## Services

- \* Welding Need to do that odd welding job or need a dry place to work on your Land Rover? I live in Ash Vale near Aldershot and have a large double garage and Mig welder. HBRO members are welcome to use both. I can do welding for you but I'm purely an amateur, no guarantee on quality. All I ask is a donation toward cost of electricity, welding gas & wire etc. Call Roger Hardwick on 01252-335708 day, 01252-376797 evenings or email me at roger.hardwick@ntlworld.com
- \* Hoods & Tilts etc.:- For all standard models of Land Rover, or made to measure for specials, in khaki, blue or green. Soft windows put in from new or added to old tilts. Seat covers made, any upholstery made. Repairs to hoods upholstery, tents, etc. There are very few people offering this kind of service. Call Lorraine and Jeff Heydon in Alfreton, Derbyshire on 01623-552309 or 01773-830551.
- \* Roll-bars In stock or made to order. Fabrication and welding service available from BS certificated welder. Call Neville Dewdney in Ashvale on 01252-650212.
- \* VIDEOS Professionally made videos produced and distributed. Contact Dave Jeffery of "4-WHEEL FILMS" on 020-8715-4861 or e-mail David@fwfilms.freemove.co.uk.

- \* Welding and Fabrication Rollover protection, fuel tanks, & any other metal fabrication. Examples:- LR full external cage £280. Fuel tanks from £65. Dave Middleton. 07879-634772.



## HBRO On-Line

Don't forget to visit our Web site at:-

[www.hbro.co.uk](http://www.hbro.co.uk)

Also see [www.the-arc.co.uk](http://www.the-arc.co.uk)



## Copyright Notice:-

Unless otherwise indicated, articles and items in this newsletter (except those that refer to forthcoming events) may be reproduced without prior permission on condition that the author and the HBRO are acknowledged. References to forthcoming events may be published only with prior written permission.

## Disclaimer

Views and opinions expressed in this publication are not necessarily those of the Club or its Committee. You should seek to verify any information, data or technical information especially where safety, finance or legislation matters are concerned.

All business advertisements in Pants & Barks are placed on a commercial basis by the companies and individuals concerned. The inclusion of an advertisement is not an endorsement by Hants & Berks Rover Owners of the company concerned or its products and services.

Why drive a diesel when you could be driving a V8?  
 Call us for LPG Conversions on all Land Rover models.  
 50% fuel saving, equivalent to 30 mpg in a Range Rover.

Reduce harmful emissions by up to 75%

Conversions from £950 + vat

**DRIVE BY GAS LTD**

JUL00

Call Geoff Dear, LPGA Certificated installer on

Tel: 02380-422422, Fax: 02380-437381

E-mail:- info@drivebygas.co.uk Web site:- www.drivebygas.co.uk

Unit 2, 362b Spring Road, Sholing, Southampton, HANTS  
 SO19 2PB

Ready to run converted vehicles available from stock.



Specialist in Discoverys and all Land Rovers

**FIXED PRICE SERVICING**

**ALL REPAIR WORK UNDERTAKEN**

**COMPETITIVE PRICES FOR CLUTCHES,  
 BRAKES, EXHAUSTS ETC.**

**PRE-PURCHASE INSPECTIONS**

**ADVICE ALWAYS AVAILABLE**

**SERVICING AND MOST WORK UNDERTAKEN MOBILE**

**WE COME TO YOU**

**CONTACT PAUL BASS ON:-**

**TEL: 01252-690887 FAX 01276-452737 MOBILE: 0836-713677**

AUG00

## Competition Event Information

- Events are open to all paid-up HBRO members. Bring your membership card.
- ARC rules apply. Don't forget your MOT certificate where applicable.
- Entries to be on an official HBRO Entry Form.
- 2000 ARC Handbooks are now available. Contact the Secretary or the Competition Secretary if you haven't got one yet.
- All HBRO RTVs are qualifying rounds for the "Red Leader Shield" (standard class Leaf sprung LR), the "Pilot Trophy" (Standard Range Rover) and the "Performance Trophy" (for 90s)
- When you come to help set out the sections on the day before the competition, please find the Clerk of the Course (or whoever is in charge at the time) and sign on the attendance sheet. The event insurance covers those members setting up the event and is there for your benefit; but it is valid only if you sign to say that you are there.
- Please help to marshal the event. Attend the marshals briefing and then ask an experienced marshal for guidance on how to score and how to assist in the safe running of the event. We'll show you how to score if you've not done it before. A Marshalling Guide booklet is available on request.
- If you are interested in scrutineering, please ask to accompany one of the scrutineers on the day. They'll show you how the checks are done and what to look for. A Scrutineering Guide booklet is available on request.

May 26 - 28	ARC National Rally. Newnham Park, Plymouth. Devon & Cornwall LRC. See www.ARC2001.co.uk Follow-on rally - HBRO intend to stay at Newnham Park. More on this later.
June 15 - 17	RTV Hook End Farm.
June 23 - 30	Week Camping Rally at Roundhills.
July 8	Public Scenic Drive. Slab Common.
July 13 - 15	RTV / camping at Bowhill Farm.
July 20 - 22	Billing Off Road Show hosted by Land Rover Enthusiast.
Early August	RTV. Battlehurst Farm.
August 23 - 27	RTV / Camping at Nelly's Dell.
August 25 - 27	Town & Country Festival, Stoneleigh Park, Coventry. Camping, caravanning. Details soon.
Sept 9 - 10	Major's Trial. Eastnor.
Oct 6	HBRO AGM Lawns Motel, 6:30 followed by a quiz.
Nov 25	Public Scenic Drive. Slab Common. <b>CANCELLED</b>
Dec 8	Xmas Dinner. The Grange, Alton.