

Pants & Barks

January 1995

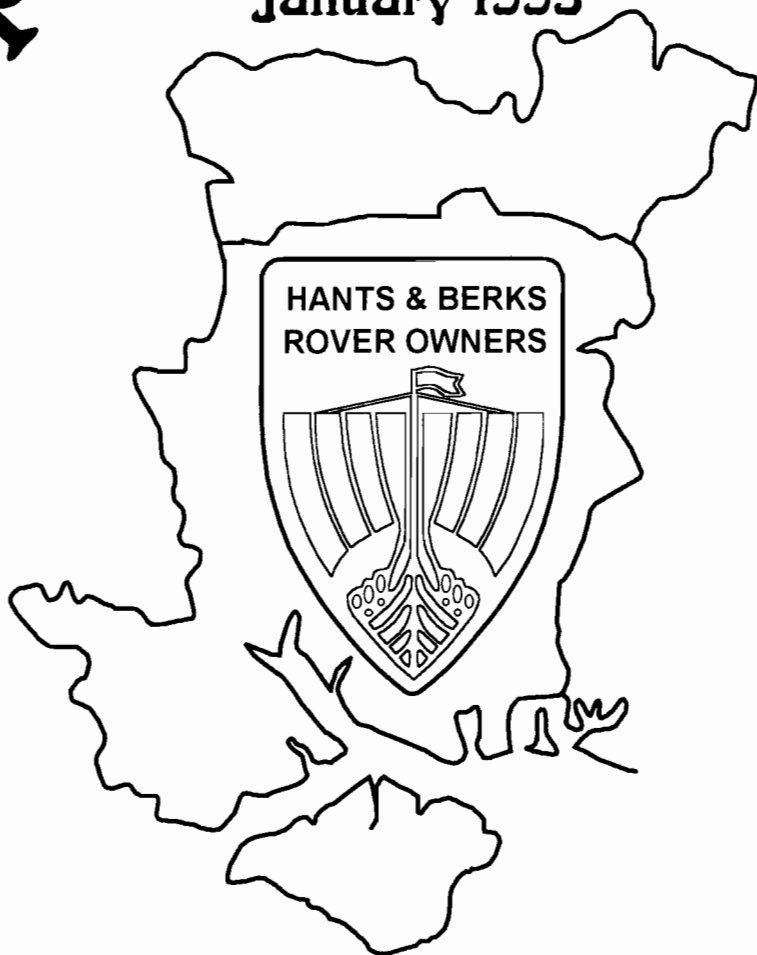

**Newsletter of the Hants
and Berks Rover Owners**

Officers of the Club

*CHAIRMAN	Nick Woodage 22 Sherwood Close, Liss Forest, HANTS GU33 7BT	☎ 01730-894418 Mobile 0850-408161
*SECRETARY	Gary Langton, Flat 1, Hillside Court 16 Solent Road, Drayton, Portsmouth, HAMPSHIRE PO6 1HH	☎ 01705-388929
*COMPETITION SECRETARY	Ashley Pocock, 132 Badshot Park, Badshot Lea SURREY. GU9 9NF	☎ 01252-310893
*TREASURER,	Alan Smith 34 Kingsmead, Frimley Green, SURREY GU16 6LU	☎ 01252-835821 Fax 01252-334600
*RIGHTS OF WAY OFFICER	Steve Kirby, 244 Staines Road, Twickenham, MIDDLESEX TW2 5AR	☎ 0181-894-3961 ☎ 0181-287-0377
MEMBERSHIP SECRETARY & NEWSLETTER DISTRIBUTION	Judith Frisby, 16, Lunds Farm Road, Woodley, Reading, BERKS, RG5 4PY	
SCRUTINEERS	Steve Kirby #, Chris Homewood, Neil Shawyer.	
ROVER RESCUE CO-ORDINATOR	John Dowdeswell, 18 Lechlade Gardens, Fareham, HAMPSHIRE PO15 6HF	☎ 01329-310623
NEWSLETTER EDITOR	Steve Kirby, (address above)	☎ 0181-894-3961

Notes:- * denotes committee member.
denotes members of ARC Scrutineering Committee.

"Hants & Berks Rover Owners" is a member of the ARC (Association of Rover Clubs), the RACMSA (RAC Motor Sports Association) and the ACSMC (Association of Central Southern Motor Clubs.)

Editorial...

May I start by wishing all our members a Prosperous New Year.

So what's in the mag this month?

- Green Lane News.
- Report on Nellies Dell Trial.
- ARC meeting report.
- Norwegian Trip News.
- Rule change proposal changes (!) *

* I did receive a set of responses from one member (we have a reader!). His views are very close to my own so any suggested amendments to the proposals reflect my, and one other member's, views. A list of amendments appears on pages 16 - 17. So compare them to the list published recently, consider them and let me have your views as to whether you agree with the amendment or not so I can represent the views of HBRO when the time to vote comes along. The first vote will be to accept or reject the amendments followed by a final vote on the original OR amended proposal. I hope you all understand that!!

Brick Kiln Farm report will be held over to Feb's issue.

Last month I mentioned the fine Land Rover models available via Alan Smith. Well, he brought a few samples along to the pub meet. They are indeed fine models, detailed in some instances down to the u/j's on the prop shafts. Prices will be in the region of £35 - £40 but I must repeat, these are professionally made models, not toys.

Forthcoming events. Please don't assume that your editor knows about everything that is going on. Please forward details to me at the address opposite or the phone / fax numbers listed below. If published details are wrong or need to be changed, please let me know ASAP.

In order to get the newsletter to you by a reasonable time, everything must get to me by the 20th of the month absolute latest. If you are posting something to me, give me a call to let me know it's coming in case it gets delayed. If you use a PC, please send articles on disc (3½" or 5¼") and I'll return it afterwards. If you have a fax machine, send any faxes to 0181-562-6660 marked "FAO: Steve Kirby" and if you can't get me on the phone at home, leave a message on the answering machine on 0181-562-9604. Thanks.

Green Lane News

Since I haven't received any threatening phone calls, and my dogs haven't been staked out on the back lawn, I'll presume that most of you are happy enough to let me do the laning organising. However, the other side of the coin is that no-one has given me any suggestions - so if something I moot doesn't suit, let me know.

DATES

As some of you know, I work an irregular 10-day shift system which prevents me from guaranteeing having regular days off... which includes weekends. Despite my initial (hurried) thoughts on the subject, no-one in the club has been able to tell me why the 'second-Sunday-in-the-month' routine needs to be set in concrete; indeed, a lot of people have said they would prefer a bit more notice, so one fairly major change that I am going to implement up front is to be more flexible with the dates; I know (more or less) when I am working up until April 1995, so at the end of this article I am offering the dates on which I propose to organise the laning for the club; the obvious change being that there are far more of them, and hopefully, it'll mean more choice for people who want to explore.

I'm reading P&B for December and I see that the dates for the Winter Trials Series haven't been set for January & February. Needless to say if they clash with my proposed laning dates the laning will be put on hold.

VENUES

Since the club covers such a large area, I thought it would even out the travelling if we loosely alternated the venue between the two counties monthly; we'll start with Berkshire / Wiltshire for the simple reason that I know that my set of Berkshire maps is right up-to-date and I might be able to get over to Salisbury to do the Wiltshires before the day; just coz we're the H & B doesn't stop us exploring the adjacent areas. So... for the 8th January the venue is Sheet 174 SU362734 meeting in the PH carpark 0930. Hopefully the Rickshaw Ramble won't have left everyone exhausted.

I'm off to Wales for a 2 to 3 day bash over the weekend of 13th-15th January; anyone fancy coming to play? We've got a few lanes in mind, Hugh Glossop has very kindly volunteered (like he needed encouragement?) to act as tour guide; it'll be B&B overnight, and none of your hairy-chested Hard-Man-Under-Canvas routine. Please phone me SOONEST if you're interested; believe it or not I'm writing this on the 28 November 1994 but by the time you read it there won't be that much notice....

MAPS

I've got the maps from Adrian, and I'm in the process of marking them up to 94 standards; a list will appear in a later issue. I am happy to supply people with a marked-up-and-labelled map, send me £6.00 to enable me to buy one and post it back. (This is **not** part of a scheme to get me to Hawaii next summer- it takes a long time to mark up a map properly, so take advantage of my good nature). Obviously the list may grow with time - NB Landrangers only.

The Club maps will be available on a borrow-and-sign-for basis. Since they are expensive and nicely biodegradable when mixed with water I am seeking approval to levy a 50p-a-map charge to finance replacements.

RULES

I hear you say, 'Rules?? Wots 'e on abart????' But I think that it might be appropriate to emphasize that collective HBRO laning will be planned and undertaken within the confines of the Law, i.e. we'll only be driving on RoW as published by a Definitive Map. Anyone undertaking laning outwith the published routes does so 'on their own', and will **not** be supported by the club in the event of an infraction; they would probably find themselves expelled from the club if circumstances warrant. Without being elitist, the club has rules, if someone disagrees with them they should either put their point of view in an appropriate manner or withdraw from club activities. Clubs have been prosecuted in the past for the activities of their members.

So out with the diaries....venues will be published an issue in advance and will to a certain extent depend on who has phoned me beforehand. Democracy rules, if thats all right with everyone else.

REPORT SHEETS

I'll be compiling travelogue / survey forms for members use and will distribute them at pub meets. Let me know if they're any use.

REPORT of the LANING TRIP 16/12/94

Six cars, 3 RRs, 2 SWB and a Discovery gathered at MaidenCourt Farm SU373760 to set off around and on the Ridgeway. First abuse of the day came from the farmer, who 'can't stop you' but one day we'll have you all banned'. Correct to the first, wrong to the second. We found a sign stuck over a Berks CC RUPP sign that said 'Permitted Path', that's a new one, anyone any clues??? We wound our way onto the Ridgeway, headed East, and tackled a few of the lanes around East Ilsley which don't have VRs (Voluntary Restraints) on them.

We finished up on the Shrill Down and Several Down, both of which showed evidence of little recent use. Anyway, it was a lovely day, we saw loadsa bunnies and deer doodoo, we had lots of practice at trimming trees so that Mother Nature didn't get too friendly with the Discovery, and guess what, just when we thought we were in an abuse-free zone, we got some more abuse, this time from a lady who thought we were 'treating the road like a motorway'. Since at the time we were trying to get onto a metalled road through concrete posts set 6' apart I refrained from pointing out that we were nowhere near the 70 mph limit. Anyway, I hope my intial attempt went down OK, thanks to Ian Rose, Bob Mills, Joe Irwin, Peter Webb and Jeff Collarbone.

DORA

No, I've not started a dating service, this stands for Disabled Off-Road Access, which is a (very) loose organisation aimed at providing, can you guess, access to off-road areas for disabled people. There is a meeting at Stevenage Off-Road Site (just off the A1M) on 2nd February; £11.00 admission per vehicle, which includes the cost of a (compulsory) wheel wash. The aim is not to carry disabled people on this day, but to have a non-damaging 'liaison day' at which all the clubs can meet and thrash out schemes and projects. Contact Mick Fox, 01923-444958 for further details.

Mike Dyer

Steve's bit....

Definitive Map:-

We now have an update on the Berkshire Definitive Map. The old one has been altered to align with the new one so we have TWO current copies. The "driveable" rights of way have been marked with a yellow "hi-lite" pen and the county boundaries with an orange one. Look out for TROs - Traffic Regulation Orders. These will be clearly posted and mean that you can't use the lane. If you wish to borrow one of the maps to transfer details to your own LandRanger or Pathfinder maps, ask Steve Kirby or Mick Dyer to lend you one of them. Alternatively, one will be brought to each pub meet so bring your maps along. Scale is 1:10,000. To give you an idea how detailed that is, individual houses and gardens are shown - and that's for the whole county. So if you've built a conservatory without planning permission, we can check! (only kidding). Also available is the Definitive Statement. This is a book that describes in words the ends of EVERY right of way in the county. For example:-

"Aldermaston number 7. Byway.

FROM: Burghfield to Kingsclere road opp Decoy Pond, S.

TO: Silchester Road at Tadley Common, 370 metres (400 yards) W of the

Pelican Inn" How about that. There's no excuse for not being able to find the ends!

If anyone has access to the Hampshire Definitive, let Steve or Mick know so we can update our own or the club set. Oh! Didn't you know? Following a generous donation by Nick Jennings a while ago, the club has a set of the 1:25,000 scale Pathfinder maps for the whole of Hampshire AND Berkshire. These are reasonably up to date but they'll need a thorough check soon. With all these maps available, there's no excuse for straying off the right of way. You will get no support from the club if you get caught trespassing as it's a serious offence. With the high levels of security patrols in and around the Royal parks and military land... well, need we say more?

Steve Kirby

<u>GREEN LANING DATES</u>		
Jan	8 13-14-15 22	Berks/Wilts Sheet 174 SU362734 meeting in the PH carpark 0930 Wales Hants
Feb	5	Berks/Oxon
Mar	12 26	Herts Hants
Apr	16 26	Berks Wilts

Copyright Notice:-

Unless otherwise indicated, articles and items in this newsletter (except those that refer to forthcoming events) may be reproduced without prior permission on condition that the author and the HBRO are acknowledged. References to forthcoming events may be published only with prior written permission.

RTV & CCV Trial Brick Kiln farm, Alton, January 15th

We are holding an RTV and CCV trial at Brick Kiln Farm near Alton, HANTS. The site is right next to the steam railway. The event will be open to all fully paid-up members of HBRO. Entries should be on an official entry form if possible. The fee is £10 in advance or £12 on the day. Payment to Gary Langton. (Address inside front cover.)

Scrutineering starts at 08:30.a.m. and the competition will start at 10:00.a.m. prompt, so please be on time. Classes will be as per ARC rules but experience has shown that amalgamations are probable. You should all have your 1995 ARC Handbooks by now. If you haven't, call Gary Langton or Steve Kirby for one. These contain the new vehicle regulations (Those in the 1987 and 1989 ARC Yearbooks are out of date.) It is still up to you to ensure your vehicle complies. Don't forget your MOT certificates, and driving / RACMSA competition licence.

RTV will be a qualifying round for the "Red Leader Shield" and the "Pilot Trophy" RTV and CCVT will be a qualifying round of the Winter Series.

Please come along on Saturday to help set out the sections, it's always the same few who get lumbered with this. On the Sunday, please enrol as a marshal once in a while, we'll show you how to score if you've not done it before!

Finally, please don't all rush off at the end: those who add up the scores and deal with the paperwork need a bit of help. It's always the same few who do it. Thanks.

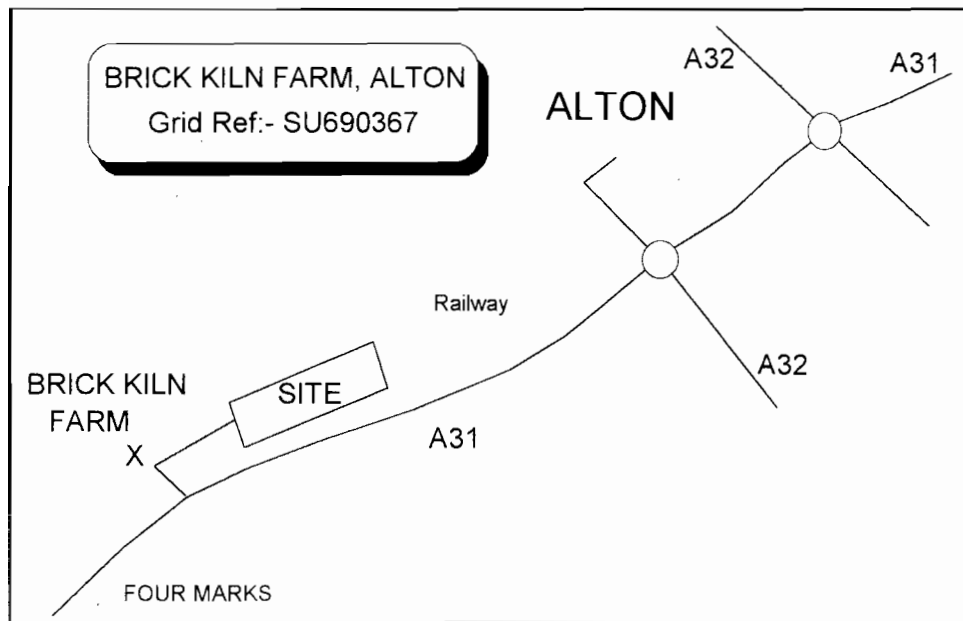

Nellies Dell 20th Nov.

On arrival, we were told that it was slippery on the hill getting into the site. "So how come 2-cylinder Gary made it?" After signing on, it was good to see some new faces as well as the usual old ones. A good turn-out for a good site.

Section one. Looked OK at first. A straightforward grass bank - but after two or three vehicles it was getting slippery. Then there was a drop down with a hard right turn at the bottom that caught a lot out; it was hard to stay in control and miss the cane.

Section two. Looked OK but watch out for logs along the side of the track; then over a slippery bank at which only the driver of a 90 made it look easy.

Section three. I had to bump start it as I went down the ridge and then up the bank a sharp right turn back down; bump start it again and then to the finish. Then out with the tools to adjust the carb!

Section four. A tricky start here that caught a few out and then the finish was over some tree roots and up the hill. I made the hill but took out the "one" cane then slid to the bottom sideways!

Section five was on the old railway embankment which was slippery and good fun. Most were caught out at the beginning. I cleared it but ended up with a dent in the roof.

Section six. The reverse of five so by now even more slippery.

Section seven. Quick work by Nick setting this one out. Round the old chalk pit with parts of section 1, 2, 3 and 4 in it; well done to Hugh, the only one to clear it. Shame about the dent in the wheel rim though.

Thank you to all the officials and marshals without whom the event would not have taken place.

RTV RESULTS:-

Class 2; B. Simpson - 16 A. Simpson - 19 C. McGeache - 38

Class 3; Neville Dewdney - 9

Class 4; Hugh Duffett - 26 S. Pincott - 37 Nick Jennings - 37

Alan Smith - 53

Class 5; Steve Kirby - 18 Paul Webb - 35 Keith Jones - 36

Mick Dyer - 50

Class 7; Richard Emery - 22

CCVT RESULTS:-

John Tester - 35 Brian Frankland - 36 David Foster - 49 Mark Tester - 50

Gary King - 61

Neville Dewdney

ARC Meeting. 10th December.

I was on my own for this one. Won't anyone come with me to these meetings now that Adrian's interests have taken him elsewhere? There's lots of interesting(ish) things going on but to be fair, you would need to be fairly meeting-orientated to keep the interest going!

As usual, I have produced highlights from notes taken at the time and are not guaranteed to be free of bias. Numbers refer to agenda items. Agendas are available for viewing if you wish and the official minutes are printed in ARC's own newsletter, Rover Runes, copies of which are available by writing to the ARC Secretary.

5. Chairman. Peter Oakden.

- Paul Entwistle, editor of Land Rover World (LRW) wants to work with the ARC
- Gaydon. Reminder that this event is on July 14-16 1995. BBQ Saturday p.m. Rover jumble sale. Lectures. S/H cars and Land Rovers. "Old Boys" reunion. LRW support. Restoration teach-in. Driving tests. (Land Rovers Sat, Cars Sun.) Off-Road course may be available (To Rover club members, not general public) 25 years of Range Rover celebration. Tickets as last year.

6. Secretary. Andy Stavordale.

- Tom Flynn from Scotland wants to form a new club.
- There is more advertising in Runes.
- RRR is no longer a competitive club as of NOW. (As a Register member. I am disgusted at not being informed of this. - Ed.)
- Andy sent a complementary copy of the handbook to a Swedish club (not affiliated). They liked it so much, they asked for a dozen or so. On being told the price, they decided it was cheaper to affiliate to the ARC and get the copies free!
- It costs £70 to send yearbooks to all overseas clubs. Many don't make any reply at all. Should we restrict the circulation to those who bother to communicate?
- Gaydon - Clubs are requested to contribute something. Any ideas HBRO?
- SROC have offered to run the National Rally in the year 2000. (I hope they realise that this is the LAST year of the present century and NOT the first year of the new. - Ed)
- Deutsche Rover Club are holding their 20th anniversary in May 1995. Same date as ARC Nationals, unfortunately.
- Norwegian Land Rover Club are holding a 20 year of Land Rovers in Norway event at Lillehammer. Details elsewhere.

7 & 11 Treasurer's Report. Lawrence Johnson is ill so his report was read out.

- Financial status of ARC was read out but with a request not to publish the

figures. (Ask me if you want the figures - Ed.)

- Subs increase was voted at this point. Fees now £2 per members for competitive clubs and 50p per member of non-competitive clubs. Voting was 23 for, 8 against, 4 no-votes.

8. Forthcoming National Rallies

1995 - Lincs. Work progressing well. Trophies to be returned by the 1995 AGM please.

1996 - SROC - Uckfield in Essex off the A22.

1997 - 5 miles North of Porthmadoc, Snowdonia.

1998 - Lancs. and Cheshire - 50th anniversary of Land Rover. To be held somewhere centrally in England. Land Rover will almost certainly take a major interest in this event so will they offer Eastnor? Will the smaller clubs who normally wouldn't be able ever to run the Nat's on their own like to run one part of it?

1999 - Any offers.

2000 - SROC.

9 Scrutineer's report.

- Circulation of information is to all reps.
- For those clubs without a delegated rep, the info goes to the secretary.

10. New Clubs

- "Flower of Scotland 4 Wheel Drive Rover Club" applied some time back. They have now complied with all the requirements and accepted as member.
- "Heart of England LRC" run by Reg Smith. Competitive. Covers West Midlands, Cannock area, Shropshire, Staffs, Burton area. Details forwarded to clubs already covering that area to see if they object. That area is actually well covered already.

12.a) Caravans. Jim Campbell

- ACCEO is a good organisation to deal with for caravan insurance.
- The following warning was read out regarding Exemption Certificates used where planning permission has already been granted on a long-term basis. For example, a farm may have permanent permission to have, say, 5 vans at a particular location. If we use an exemption certificate to allow 25 vans there, this may make life difficult for the farmer even if we use a different part of the farm.

12 b) Overseas Liaison Officer Fran Luxton.

- Needs to trim the mailing list. We're sending out Runes, Handbooks etc. but are getting precious few replies. We should send stuff only to those who are really interested; i.e. the ones who bother to reply!
- We have found that the Internet has criticisms on it in the Land Rover

Interest section. A couple of criticisms are from Rover Clubs who don't / won't reply to the ARC's letters and yet they have the nerve to cast disparaging remarks to the rest of the World!! (Internet is a Worldwide E-mail system) Andrew Neave uses Internet and offered to look there to see what is on it about the ARC and to respond on behalf of the ARC.

12 c) Rights of Way. Tony Kempster.

- Gap Road. No TRO at the moment. Large number of protests have lead the council to defer the TRO.
- 1995 LARA conference is on 8th March. Motorsports only this time. Fee is £25 to club members. If you are interested, call 0788-541137.
- LARA held a meeting in November to publicise its activities.
- Green-laning. New Code of Conduct limits vehicles to a max. of 3.5 Tonnes.
- CLA - Country Landowners Association are having a Rights of Way Conference. ARC involvement would be a good idea as they are showing an interest in their Newsletter.

12 e) Rover Runes Magazine. Ted Ivory.

- Copy of Runes to all members? Too expensive and anyway, anything in Runes can be re-printed in the clubs newsletter if relevant.
- Advertising in Runes. It's £200 a year. That's 4 issues of only about 200 copies. Makes our rates in Pants and Berks look so cheap! At that rate we should be charging £600 per full page p.a.

12 m) Scrutineering. Dave Marsh.

- Log books - if a club needs a log-book scrutineer to attend, then phone for the nearest one!
- Photos for log-books - please have them ready so one of the two scrutineers who examines the vehicle can sign on them for authenticity.
- 60 log-books have been issued to date (10th December) There are about three times that amount in the system awaiting their second inspection or final issue.
- Roll-bars - design to be harmonise nation-wide. Discussions have taken place and draft proposals published. There are there basic types of installation to consider:-
 - 1) Chassis
 - 2) Monocoque
 - 3) Space frame.

There are tube specs. and mounting designs to sort out. The good news so far is that the working group (RACMSA, ARC, AWDC, Anglian, NORC and some others) have recognised the ARC's experience with mounting roll-bars on a chassis and have accepted the ARC designs for ALL vehicles with a "proper" chassis. They also recognise that our spec is actually very high and that any subsequent rulings SHOULD mean that ARC members will not have to alter their vehicles should a nation-wide set of regulation come into

force.

There are some weight categories being introduced. The >1000kg group (that's us!) will be able to use 48mm Ø / 3.2mm wall Blue-band tube (as at present) or 44mm Ø / 2.5mm wall CDS tube. The RACMSA are to establish some scientific tests to see what thickness mount plates are required and what size nuts and bolts to use. It's unlikely that they will find the need for plates thicker than ¼" / 6mm in which case, no mods to ARC vehicles will be needed. The RACMSA philosophy is basically to provide a roll-bar that will protect the occupant ONCE. i.e. the vehicle may not be able to / be allowed to continue after a roll-over. The ARC philosophy has been to have the bar strong enough to enable the vehicle to continue in the event following an accident.

The ARC exemption may go from the Blue Book and we would have to accept the nation-wide (RACMSA) regs. The target for completion is 1996! If the ARC gives up its exemption, then we would want continuing input in the future.

The main problem we can foresee is that someone may have a vehicle equipped to the "lower" RACMSA standard and want to compete in an ARC event (on condition that all other requirements are complied with.)

13) AOB. The May Day Bank holiday for 1995 will be on the 8th and NOT the 1st as many diaries and calendars show. So if you got a calendar or a diary for Christmas, amend it NOW.

14) Next Meeting to be 11th or 18th March 1995.

After the meeting, Ian Davis of the RASMSA answered a few questions. The responses are in note form....

1) Fire extinguishers - Halon is still permitted. AFFF and ZERO-2000 are becoming popular.

2) Promotional events - NOT a competition. It's basically a certificate of exemption that enable members of the public to participate. Application forms must state "Request permission for public to participate." ALL participants, **including passengers**, must sign on although the vehicle itself constitutes the "entry". A promotional event (e.g scenic drive etc.) can be held at the same time and place as a competition if there is a safe distance between them.

3) Permit application form. Very important how this is filled in. Ian went through this form step-by-step. Consequently, I have a sample filled-in application form so if it affects you, see me for details.

4) Membership period prior to competing. There is no set time. Someone can compete within minutes of joining so long as all the requirements are met and that he / she is a FULL member.

Steve Kirby

20 Years of Land Rovers in Norway.

Norwegian Land Rover Klub (NLRK) is to celebrate its 20th anniversary in August 1995. The location will be at LILLEHAMMER, NORWAY, 8th to 13th August.

There will be facilities for tents, caravans and motorhomes. There will be 2 or 3 events each day to include sightseeing, Green-roading, simple trials, scenic drives, social events, etc. There is a motor museum in the town.

There are ferries from Harwich to Norway and Sweden. I have made enquiries for a special deal from a ferry company which I won't name at the moment but if anyone else has special contacts with ferry companies, please let me know. From Gothenburg, there is a 7 to 8 hour drive to Lillehammer; the trip from Bergen being 10 hours or so. Petrol is 7.50 to 8.50 NOK / litre and diesel is 6.50 NOK/litre so start saving now - it's expensive. Camping fees are 110 NOK/day. Event fee is 200 NOK for the whole stay. (NOK Norwegian Kroner) Event enquiries to:-

ERIK WINTHER-SORENSEN
KONGSSKOGEN 34
N-1370 ASKER
NORWAY
TEL: +66 98 90 03 OR +66 78 78 92.

Cabins are available but must be booked separately from:-
HUNDERFOSSEN TURISTSENTER
N-2638 FABERG
NORWAY
Tel: +47-6127-7222

Comfort level	Rooms	Beds	WC / Shower	NOK / day	NOK cleaning
1	1	2 - 3	No	250	150
2	1 - 2	4	No	420	150
3	2 - 3	4 - 5	No	580	250
4*	3	4 - 5	Yes	750	250
5*	3	5 - 6	Yes	900	250
6*	3 - 4	8	Yes	1100	250

* includes pillows and quilt. Bedlinen and towels are extra.

Please let me know if you would like to go as I have one fairly certain already on my "little list".

Steve Kirby

RTV Trial at Nellies Dell January 29th Winter Series, Third Round.

We are holding an RTV trial at Nellies Dell, about 6 miles south of Alton, HANTS beside the A32. The event will be open to all fully paid-up members of HBRO. Entries should be on an official entry form if possible. The fee is £10 in advance or £12 on the day. Payment to Gary Langton. (Address inside front cover.)

Scrutineering starts at 08:30.a.m. and the competition will start at 10:00.a.m. prompt, so please be on time. Classes will be as per ARC rules but experience has shown that amalgamations are probable. You should all have your 1995 ARC Handbooks by now. If you haven't, call Gary Langton or Steve Kirby for one. These contain the new vehicle regulations (Those in the 1987 and 1989 ARC Yearbooks are out of date.). It is still up to you to ensure your vehicle complies. Don't forget your MOT certificates, and driving / RACMSA competition licence.

RTV will be a qualifying round for the "Red Leader Shield" and the "Pilot Trophy" RTV and CCVT will be a qualifying round of the Winter Series.

Please come along on Saturday to help set out the sections, it's always the same few who get lumbered with this. On the Sunday, please enrol as a marshal once in a while, we'll show you how to score if you've not done it before!

Finally, please don't all rush off at the end: those who add up the scores and deal with the paperwork need a bit of help. It's always the same few who do it. Thanks.

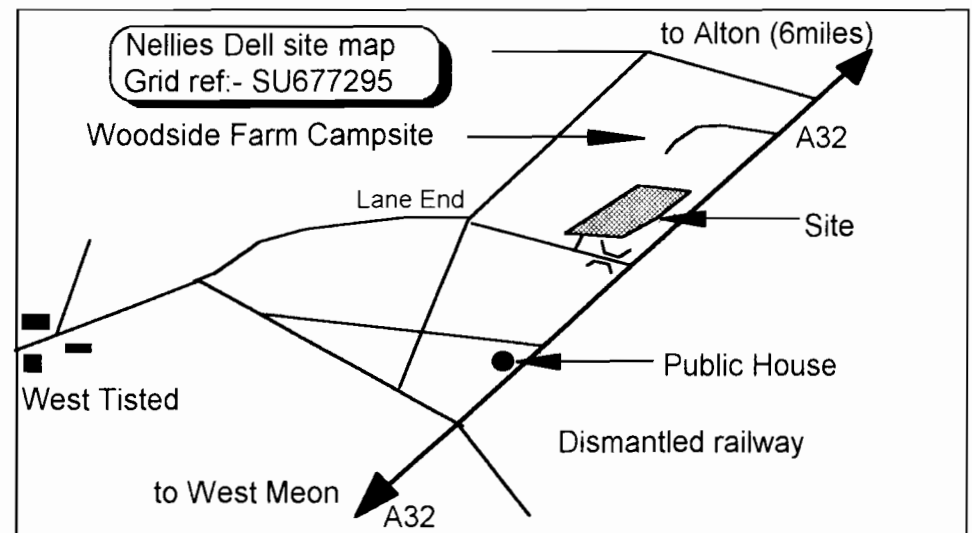

ARC Rule Change Proposals.

Some of the proposals printed recently have had amendments raised against them following a meeting of the scrutineering representatives at Solihull. The details are as follows:-

B Locking Differentials. Amendment suggested such that the rule applies only to RTV's.

E Roll-bar widths. Amendment suggested. Drawings and associated text to be removed from the proposal and the wording from the 1995 Handbook be re-instated less the word "full". So the amendment is to re-instate the following (slightly modified) paragraph:-

The roll-bar main hoop and the windscreen hoop (if fitted) will run across the width of the vehicle. Its height will be determined by the requirement for there to be a distance of at least 50mm / 2" from the top of the driver's head (when crash-helmeted as applicable) to the top of the bar and be as wide as possible within the vehicle's body.

F Roll-bar regs (Contents) Several minor detail changes suggested:-

- i) Change to roll-bar width text already mentioned in E above.
- ii) "Internal main Hoop with External Front Hoop" - request to show alternative positions of rear braces. See N below.
- iii) "Front Hoop Designs and Attachments" - Scottish ROC proposed:-
 - a) Change word "doubler" to "spreader" in two places.
 - b) If the front hoop can be offset to front and rear of outrigger, then it can be similarly offset outboard. This was agreed.
- iv) "Front Hoop Mounting to Outrigger on SI-III & 90 / 110 etc." YROC proposed:-
 - a) Indicate that there is to be no gap between the top of the outrigger and the saddle (or any existing gap to be filled with a metal plate.)
 - b) Dimensions of the saddle to be specified.
- v) Main Hoop design for Range Rover and Discovery to be identified as suitable for Long Wheelbase Station Wagons. Two places.
- vi) It has always been accepted that the main hoops and the diagonal brace should each be made in one piece. So to that end, the scrutineering committee suggested that the paragraph on page 103 of the 1995 Handbook be amended to read:-

All hoops (main and front) and the diagonal shall each be made of one continuous piece of tube. Bracing bars, both rear and diagonal, may be made detachable or jointed as specified later.

vii) At the ARC meeting on the 10th December, Ian Davis of the RACMSA commented on the submission of Supplementary Regulations (SRs) with the event permit applications. Because we have SRs incorporated in the rules, each club has to declare these each time. If the word "Supplementary" were to be changed or just removed, this requirement would be unnecessary. For example the wording "Section E. Road Taxed Vehicle Trial Supplementary Regulations" in the Handbook would become "Section E. Road Taxed Vehicle Trial Regulations". The rules themselves would be quite unchanged.

H Bolted roll-bar mounts on foreign registered vehicles. Proposal changed to highlight bolt sizes. Text under drawing to be:-

The main hoop mount is the same as the "old" bolted design and attachment is by the usual 3/8" / 10mm HT mounting bolts.

I Fire extinguishers. Small amendment to add a statement recommending that minimum size should be 2.5kg.

K Non-standard carburation. "Carburettors" amended to "Chokes". Rest of proposal unchanged. Note that this rule (in either format) would preclude the use of engines of 3.9 litres or larger being converted to carbs as they had no carbs in the first place.

L Extra bars on roll-cages. Proposal to apply only to open vehicles. Otherwise unchanged

M 2½ litre engines in Series Ones. Suggested amendment to allow 5-bearing crank engine as well but only in Trials Class 2.

N Roll-cage design. Proposal amended. See drawings below.

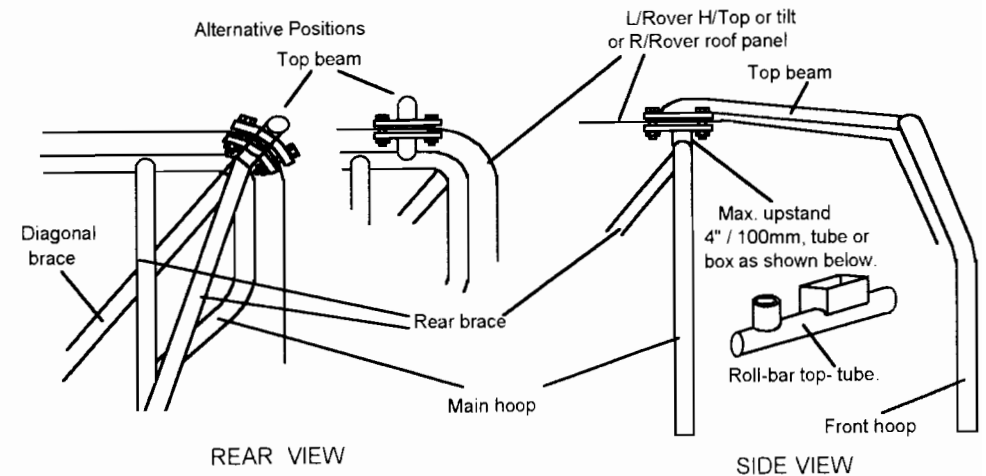

O Throttle return springs. Amended such that the proposal regarding throttle springs will explicitly include diesel and fuel injected models not currently

covered and will mean ANY engines, whether fitted with springs on production or not, will now need an additional spring.

Q Aggressive tyres. General SR D.5.2. already covers this but it was agreed to leave the proposal unchanged.

=====

Any responses to be sent to Steve Kirby so he can report back which amendments are accepted and which ones are to be rejected. Once this decision has been made, final voting can be taken on the resulting proposal. The final results of the voting will be announced at the AGM in March 1995. Those rule change proposals which are approved will become valid in January 1996 (unless specifically recommended for earlier or later implementation).

Steve Kirby

Technical Topics

The Scrutineering Representative's meeting of December 3rd mentioned on page 16 also raised some discussion topics. If you have any input to make on these items, please let me know. Thanks.

a) Log Books.

1) Either of the Log-book scrutineers will be signing on the face of each of the photos submitted so please ask your members to have the pictures available before the second inspection.

2) Removal of identity tag and impounding of log-book following serious damage to the vehicle. Exactly at which point this takes place is a matter for debate. If in doubt, call one of the log-book scrutineers. If the roll-bar is extensively damaged and / or is to be replaced, then the identity tag will have to be removed by the event scrutineer and the log-book impounded. These items to be returned to the Log-Book secretary. A complete cycle of inspections will then be needed for the repaired or new roll-bar / cage.

b) Hydraulic hand-brakes.

It is permissible to have a hydraulic hand-brake operating on the main braking system only on a Special.

c) Fuel tank vents were discussed.

Rule A.11.1. mentions "...a self sealing vent..."

In practice, very few vehicles have sealed tanks. For a vehicle where the tank has an extended vent pipe, most builders incorporate a long loop which prevents leakage in the vent of a roll-over. Some have fitted a one-way valve to let air in as fuel is used but which prevents spillage in a roll-over. The problem with these is that if the system pressurises with a change of atmospheric pressure or temperature or simply by the petrol evaporating, this type of valve can cause fuel to be forced into the carb(s). Flooded engines and garages have resulted from this with the attendant potential engine damage or fire risk. More discussion is needed.

d) Ram -type power steering.

Commercial kits are now available to fit power steering to Series I, II and IIIs. (National Power Steering and Ian Ashcroft.) These add extra components to an existing vehicle - the manual steering box and relay remain in-place. The designs are close copies of the Land Rover Santana power-steering kits, now no longer available. Are they legal?

e) Drilled radius arms.

The rules have no specific statement prohibiting this but is generally considered to be unwise.

f) Sport steering boxes.

These have 2½ turns lock-to-lock compared to the normal 3½ or so. These are in widespread use already but offer an alternative to the practice of drilling the pitman arm nearer the hub which is definitely not allowed.

g) Manual Range Rover type steering box on Series I, II and IIIs.

Rule B.2.1. appears to allow this and the vehicle remain Standard. The steering relay appears to be a weak link in the system.

h) Coil-over dampers.

The rules say that springs must have Rover or equivalent part numbers and rule A.10.1. allows coil-overs (presumably regardless of make as Rover don't make any.). There are some vehicles that are using ONLY coil-overs; the original springs and spring mounts have been removed. The rules don't seem to prohibit this.

i) Numbering of Roll-bar regs.

The Roll-bar regs are to be numbered along the same lines as the main rules. This should facilitate reference to certain paragraphs for future changes etc.

Any comments?

Steve Kirby

Regular Competitor?

If you pre-enter HBRO events on a regular basis, please let Steve Kirby or Adrian Bolge know and we'll send a wad of entry forms. In the past, we sent these in P&B to everyone 3 or 4 times a year but only about half a dozen members pre-enter on a regular basis; hence most of you are amassing a stack of waste paper. We have worked out that it's cheaper to send forms directly to those who need them most, so it is for them that we offer this service.

Winter Series

There will be a repeat of the Winter Trials Series again this Winter. (What a good time to have a Winter Series) There will be four qualifying events, each of which will be a "free-standing" trial with awards of some kind. To qualify for the Series Trophy, competitors **must** officiate at one and compete in the other three. If they miss one competing event, then they may opt to accept a set penalty to keep them in the running. Locations to be advised but will probably be two each at Brick Kiln Farm and Nellie's Dell.

LAND ROVER MODELS

Anyone interested in scale models of Land Rover vehicles? I can obtain for HBRO members a selection of models as built or kit at very good discounts. The range is quite extensive, please send stamp addressed envelope to A. Smith, 34, Kingsmead, Frimley Green, Surrey GU16 6LU for more details.

The models can be customised to represent your own vehicle at no extra cost. I must point out that these models are collector's models and are not suitable for children. I must declare that these models are not produced by myself but are produced by a well established company who specialise in Land Rover models. Other models are available if the interest is there. The HBRO will gain a small income from the sales, but even so the discounts offered are very attractive. Would you like to see regular articles on scale models appear in the monthly magazine? Please enclose stamped addressed envelope if you require a reply to your correspondence.

Alan Smith.

Members' Discounts

Company	Facilities	Discounts etc.
Brooklyn Engineering 0703-252281 0703-269990 (fax)	Spares, servicing	Depends on what you are buying, but about trade prices.
RoverTune. 0734-842777, 0734-842000, 0860-560556 0734-843019 (fax)	Spares (new and s/h), servicing. (Range Rovers a speciality)	Trade prices, regular special offers.
Wadham Kenning, Guildford	Vehicle sales, spares, servicing	To be advised.
J.W. Clark's Exhaust and tyres 0705-671231	Exhaust systems, tyres. Good selection of exhausts from Series One to RR.	Trade price less 10%
Urquharts, Petersfield. 0730-261022	Spares.	Cost+20% on non-franchise parts. Trade price on others.
Country 4x4, Terry Vincent, Calcott, Reading. 0734-412412, 0836-577892	Spares (new & s/h), servicing. (Range Rovers only). Custom bull-bars by SIMBARS.	No set discount but very hard to beat prices!
Southern Winch Centre, Southampton. 0703-270600	Superwinch, Warn, Ramsey, Rule winches. Winch accessories, ropes (£2:60/m incl loops), Hi-lift jacks, spotlights etc	Discounts vary but very competitive prices and free fitting on winches

These companies / dealers are offering discounts to HBRO members on items specified.

Don't forget to take your membership card with you!
If anyone can add to this list, please contact Steve Kirby with the details.

For Sale

Note that small ads are free but please let me know when a sale is complete so I don't keep printing an out of date ad each month. I know I forget sometimes so you may need to remind me more than once! Please help potential customers by quoting location and dialling code in your adverts. Thanx.

Commercial Adverts:- £50 for half page, £80 full page and £100 for whole back page per annum; payable in advance. These rates are very good considering the perfect targeting. Current circulation is over 200.

All adverts are dated as to their first month of publication. When they become about 6 months old, they will be dropped unless the "owners" renew them!

* Roll-bars In stock or made to order. Call Neville Dewdney in Ashvale on 01252-28185 (JAN95)

* Wheels and Tyres Five Discovery steel wheels with 225x16 BFGoodrich Mud Terrains. Only 3000 miles, i.e. hardly used. Sell as set for around £300. Contact Colin Gross in Ruislip, Middlesex on 01895-638957 (DEC94)

* Wheels and Tyres Four silver eight-spokes; three fitted with excellent 225x16 BFG All Terrains with white raised letters; one fitted with standard 205x16 radial. Will fit Rangy, Landy or Disco. Make me an offer. Gary Langton 01705-388929 (DEC94)

* Land Rover Bits. Series III hard top with side windows and alpine lights and rear door - £85. Three door tops; 1 N/S with glass - £10. 1 O/S with glass - £10. 1 N/S no glass but with runners - £5. Freewheel hubs, AVM, currently fitted to light-weight - £40 pair. Buyer collects or arrange delivery to a trial or club event. Call Nick Woodage at home on 01730-894418, Mobile 0850-408161, or Nick Jennings at home 01734-471258, Mobile 0836-604585, Business 0734-471520. Gary Langton at home 0705-388929. (NOV94)

* Caravan - CI Cadet 12. Toilet compartment, three berth plus Salou awning. Spare wheel. Many accessories. It's a 1980 model but it's still in excellent Condition. It's one owner has looked after it well. £600. Contact Len or Joyce Doughty on 0181-979-2839 or phone Steve or Pam Kirby on 0181-894-3961 or 0181-287-0377. (OCT94)

* Land Rover Bits SWB Series II truck cab body - £130. Pair Series III front half-shafts - £25 pair. Tarpaulin, 25' x 18' - £40. Ian Copplestone, Fareham, 0329-827015 (OCT94)

For Sale

* Michelin XC4 tyre. 750x16. Virtually unused; literally only a few miles. On RR wheel. £50, including wheel, £30 on its own. Ideal normal road tyre for 110 or similar. Only one though! Contact Steve Kirby in Twickenham on 0181-894-3961 or 0181-287-0377. (JAN95)

* NICK'S NICK-NACKS Two SD1 auto gearboxes, £30 each or £50 the pair. Ten Michelin 7:50x16 XCLs, £100 the lot. Various ropes and strops (call for details) Nick Jennings on 0734-471258 or 0836-604885 (SEP94)

* MICK's Miscellany Breaking Range Rover - all the bits except the engine. Any offers? SD1 manual gearbox, £50. Series Ila gearbox, good condition, £65. Front axle for 109 c/w diff and springs. Excellent swivel joints and brakes. £75. Contact Mick Maskelyne in Newbury on 0635-874013. (AUG94)

* Four Wheel vehicle trailer. £400 ono. Harvey Frost manual winch to suit; Offers. Call Peter Jeffs in Hook on 01256-768136 or 0860-695183. (NOV94)

* Parts clearout Flat type 2A heater - nearly new; £25. Pair brown cloth reclining seats on adjustable runners - will fit Land Rover OK. Good condition & comfy. £30. Good s/h 88" petrol / diesel tank, £15. Set of unused Goodrich braided steel brake hoses to suit 88" SWB LR, £25. Call Charles Best on 0276-476223 (AUG94)

* Land Rover 90 parts Petrol 2¼ engine with all accessories - £250. Land Rover 90 "A" frame link with new joint - £20. Call Robb Unsworth on 0703-260501 (AUG94)

* Series III top tail-gate. Has bigger than normal window. £30. Contact Mike Dyer on 0276-473907 (JUL94)

* Land Rover bits. SWB hard-top (no windows) with Safari rear door - £85. Series III gearbox - £50. Series I 86 / 88 windscreen (including glass and sunvisors) - £25. Incomplete vehicle: 110 chassis and wings, bulkhead, screen and truck-cab on axles. Many parts ready to put on and is complete with V8 but needs attention. - £1200. Call Chris Bowler on 0850-792374 weekends only please. (JUL94)

* Tyres Avon Rangemaster radials 7:50x16, three available, only 4mm tread. Any offers? Call Adrian in Portsmouth on 0705-377488 (AUG94)

* Range Rover parts Rear axle casing £15. Call Robb Unsworth on 0703-260501 (AUG94)

For Sale

* Chairman's Wares & Spares "Dead" tow-ropes in hemp with soft eyes - £10 each. Mountain-bike racks for tow-bars - £POA. Range Rover tow bracket - £15. Range Rover bits:- New water pump, distributor & electronic ignition, inlet manifold & Strombergs, exhaust manifolds (1½ pairs!), flywheel & part-worn clutch. Any offers? Contact Nick Woodage on 0730-894418 or Mobile 0850-408161 (JUL94)

Vehicles for Sale

* 1966 SIIa SWB Petrol Hard-top. Blue and cream. Tax and MOT for 6 months. £700 o.n.o. 01705-755561 (DEC94)

* Series III LWB Land Rover Ex-MoD. FFR spec with hard top and 12v ignition system. 2¼ litre recon petrol, manufactured in 1976; released 1984 on Q plate. 7 months MOT. 8 months tax. Springs, spring hangers, shockers, starter motor, door tops all renewed in last 6 months. £975 ono. Call Paul in Yateley on 01252-878778 (home) or 01252-860090 (work). (JAN95)

* V8 90. Carter Carb on Offenhauser inlet. BFG Mud Terrains. Safety Devices steering plate. Boarded out rear. PAS. £5500 ono. Call Simon in London on 0181-397-5716 (NOV94)

* Comp Safari Racer. Full ARC spec. Competition winner. Available with or without race-tuned 4.2 litre V8. New project forces reluctant sale. For details, call Malcolm Whitbread in the evening on 0635-201673 or during the day on mobile 0831-281914. (NOV94)

* Series IIa Land Rover AMBULANCE. White, clean and tidy. 27000 miles. Blue lights and stretchers but otherwise not equipped. Ideal for paramedics or expedition vehicle. Bargain at £1400. Private sale. Contact Chris Bashall in Dunsfold on 0483-200046 (OCT94)

* Range Rover 1984 "B"-reg, 3.9 EFi V8, 5-speed, 4-door, blue/grey, spot-lights, bull-bar, Radio-cassette, electric windows and mirrors, MOT. Needs tidying. Financial reason for sale. £3800 o.n.o. Contact Jeff Maxwell in Bracknell on 0344-885089 (NOV94)

* Series IIa Land Rover LWB. 1969. Over £3000 spent including gearbox, transmission, brakes and starter overhaul. Any reasonable offer considered. Call 0923-853151 (evenings) or mobile 0836-730006. (SEP94)

Vehicles for Sale

* FIAT PANDA CXL 1000cc 1992 K reg. (NOT 4WD version) Radio. Less than 5000miles. Blue £3250 ono.. Contact Len or Joyce Doughty on 0181-979-2839 or phone Steve or Pam Kirby on 0181-894-3961 or 0181-287-0377. (JAN95)

* Land Rover 110 chassis and wings, bulkhead, screen and truck-cab on axles. Many parts ready to put on and is complete with V8 but needs attention. - £1200. Call Chris Bowler on 0850-792374 weekends only please. (JUL94)

* 1975 SWB Land Rover Hard Top, 2¼ petrol, Full MOT, 205x16 tyres, white colour. £1150. Call Mick Maskelyne in Newbury on 0635-874013. (AUG94)

* 1960 SWB Land Rover. 2¼ petrol, soft-top. New chassis in 1992. Alloy wheels with Kelly tyres (full set of 5). Kenlowe fan. Too many new parts to mention. £2000 o.n.o. or part exchange with Range Rover. Call Paul in Emsworth on 0243-376292 (JUL94)

Wanted

* Diesel Engine. Good working order. Normally aspirated 2¼ or 2½ for Land Rover. Call Ian Pattingale in Staines on 01784-460386 (DEC94)

* Series One wings. Pair front wings for 86" Series I. Straight ones please!! Contact Charles on 0734-832559 (OCT94)

* Set 7:50x16 SATs. Part ex possible with same size road tyres. Call:- Nick Woodage at home on 01730-894418, mobile 0850-408161, or Nick Jennings at home on 01734-471258, Mobile 0836-604585, Business 0734-471520 or Gary Langton at home on 01705-388929. (NOV94)

* V8 90, "D" or "E" reg. Contact Ted Marynicz on 0666-822348 (SEP94)

* Parts wanted Good s/h or cheap swivel housing for leaf-sprung LR (one only required). Full canvas and sticks for 109". SIII rad with duff / leaking core. Call Charles Best on 0705-377488 (AUG94)

WARNING

Any adverts dated up to and including JULY 94 may disappear next month unless you renew them!

Newsletter printed by:-



KeyLink

Business Supplies and Services

79 Mitchley Avenue, Sanderstead, South Croydon, Surrey CR2 9HN
Telephone 0181-651-1861

Pressure Cleaning

Land Rover enthusiast offers low cost pressure washing service and equipment hire (with full accessories). Great for spring cleaning or assistance with restoration. Also wet sand blaster for chassis cleaning and stripping. 15 mile radius of Tadley (North Hampshire) Ring Bob Lloyd on 01734-816318 anytime.

Events for Your Diary

*First Wednesday each month, Noggin & Natter at the Hind's Head, Aldermaston. (From 7:30 p.m. Plus Land Rover related videos if possible)

*Last Wednesday each month, Noggin & Natter at the White Swan, Bank Street, Bishop's Waltham, Hants. (From 7:30 p.m.). See OS sheet 185, SU555175 approx.

*Green-lane trips will usually be on the second Sunday of the month. See list below. If this second Sunday clashes with an HBRO trial, then it may be moved to the first or third instead. Tracey will try to book trials on dates other than the second Sunday where possible. There will be someone present to indicate rights of way on the maps. It is recommended that those involved obtain current maps of Hampshire and Berkshire, or borrow the club's set. If there is a lot of rain on the few preceding days, anticipate postponement.

GREEN LANE TRIPS - see page 7

January 15th.	Trials at Brick Kiln Farm. 2nd round of the Winter Series. Details elsewhere.
January 29th	Trials at Nellies Dell. 3rd round of the Winter Series. Details elsewhere.
February Date not set.	Trials. 4th round of the Winter Series. Details later.
February 2nd	DORA Inter-Club Day. Raising awareness and funds for the disabled. Stevenage Off-Road Site (just off the A1M) £10 to play all day. Jet-wash £1. Snack bar on site. Contact is Mick Fox 01923-444958
February 19th	Trials at Nellies Dell.
March 26th	Trials at Slab Common. To be confirmed
APR 14th - 17th	Lancs & Cheshire invite to Trentham Gardens, Stoke on Trent, Staffordshire. RTV, Team Recovery, Winch Recovery, Off-Road Driving, Bike Trial, CCVT, Comp Safari. Autojumble, Camping. Details later.
MAY 8th	50th Anniversary VE day. Vintage Vehicle Rally at Chatham Dockyard, Kent. Contact D. Barrow on 01634-727777
MAY 26th - 29th	ARC National Rally, Blankney Park, Lincolnshire. Rally co-ordinator is Eric Rawlings, 01507-526847.
JULY 14 - 16	Gaydon All Rover Weekend.
AUG 8th - 13th	Norwegian Land Rover Club 20 years anniversary, LILLEHAMMER, NORWAY. Sightseeing, Green-roading, trials, social events etc. More later.
August 20th	Trials at Broxhead Common. To be confirmed.
Sept. 23rd - 24th	Bagshot Heath Off-Road Show. (provisional date)
Oct. 6th - 8th	Major's Trial & Comp at Eastnor Castle.
December 20th	Trials at Slab Common. To be confirmed.